

## Connection of the Hotwire Module to a typical Parallel Plate plasma processing system

- \* Mount the Hotwire module in any orientation near the plasma process chamber.
- \* The included HV and control connection cables are 10 feet long and may be replaced with a cable up to 50 feet long if required.
- \* Connect the AC Mains input to a grounded 110VAC 50/60 Hz power source using the supplied cable.
- \* Connect the Control cable to the RF generator "RF ON" output signal. Most RF Generators have a positive output signal (referenced to ground) that will trigger the Hotwire to produce its HV output signal. Pin #1 = positive input, Pin #2 = negative input.
- \* Mount the supplied female UHF connector to the plasma chamber's top lid or shield. Make sure that the connector flange is connected to the chamber ground (this is the return circuit back to the Hotwire - use a metal bracket or strap).
- \* Connect the supplied inductor between the connector's center conductor and the powered electrode termination (on the atmospheric side). Use the supplied Teflon insulated wire to extend the the inductor leads if necessary. It is desirable to mount the inductor as close to the powered electrode as possible.

## Operation of the Hotwire Plasma Igniter

- \* The Hotwire Plasma Igniter is a voltage doubler type high voltage power supply that includes a solid state relay and electronic timing circuit on the primary side and a current limiting resistor (3mA max.) on the secondary side.
- \* With the AC mains power (only) applied, the HV DC output will be OFF.
- \* When a DC control signal is applied, The HV DC output will turn ON and stay on for a period of time determined by the value of the timing resistor installed on the 0.2 > 20 second "One-Shot" timer circuit. For example, use a 100K ohm value for a 2 second ON time, a 200K value for 4 seconds, 500K for 10 seconds and 1 meg value for 20 seconds. This resistor is located directly under the removable top lid and is connected to the black epoxy timer module using faston type connectors.
- \* After the programmed ON time period has elapsed, the HV output will shut off. (This is independent of the control signal status.)
- \* The HV DC signal will provide a low power starting plasma that is enough to ensure easy ignition of hard to start RF plasma discharges.
- \* Once the plasma starts, the HV output of the igniter will drop to a low voltage as the majority of the output is dissipated in the current limiting resistor.
- \* The control signal input is usually obtained from the Analog control output of the RF generator - this signal is typically supplied to "announce" that the generator's RF output is ON. If this signal is not available, a control input can come from the system PLC or computer control or through an external power supply and a panel mounted switch.

**Manitou Systems Inc.**  
**12 South Street**  
**Danbury, CT 06810**  
**Tel.203.792.8797**  
**www.manitousys.com**

Title		
Hotwire Plasma Igniter Module - Connection to plasma system		
Size	Document Number	Rev
A	00003781-S Interface	0
Date:	Monday, January 09, 2006	Sheet 2 of 2
	2	1

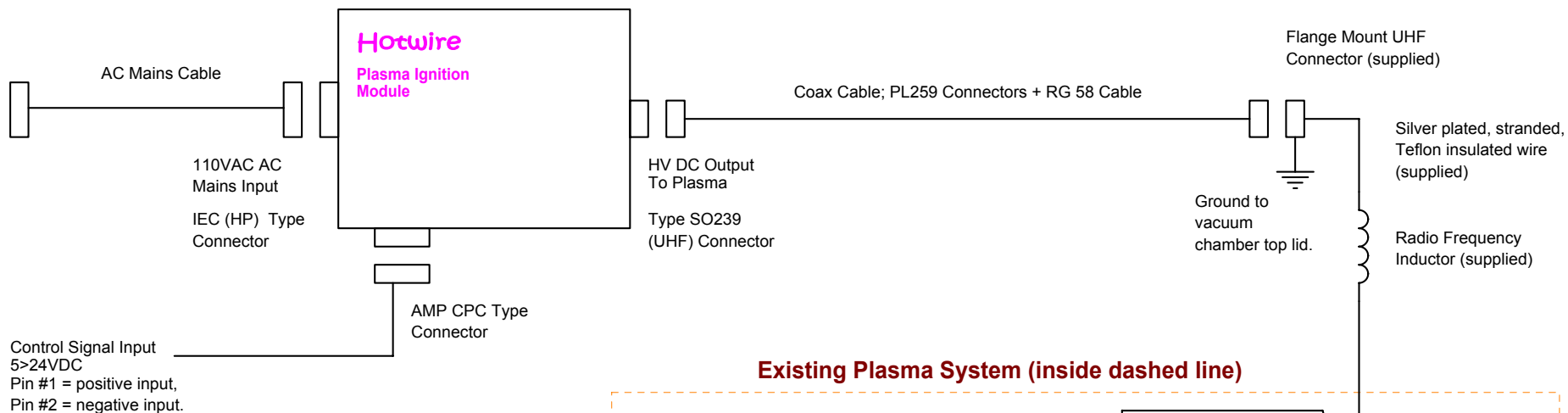

**Existing Plasma System (inside dashed line)**

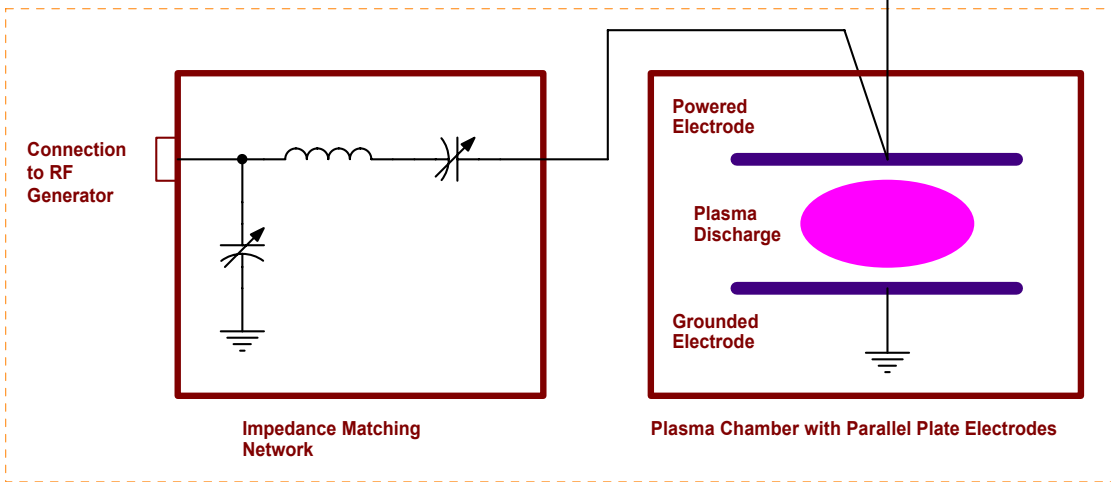

**Manitou Systems Inc.**  
**12 South Street**  
**Danbury, CT 06810**  
**Tel.203.792.8797**  
**www.manitousys.com**

Title		
Hotwire Plasma Igniter Module - Connection to plasma system		
Size	Document Number	Rev
A	00003781-S Interface	0
Date:	Monday, January 09, 2006	Sheet 1 of 2