

**DOCUMENT NO. 251010, Rev. B**

**INSTALLATION, OPERATION AND USE**

**OF POLARIS PLANAR MAGNETRON CATHODES**

**6 FEBRUARY 2003**

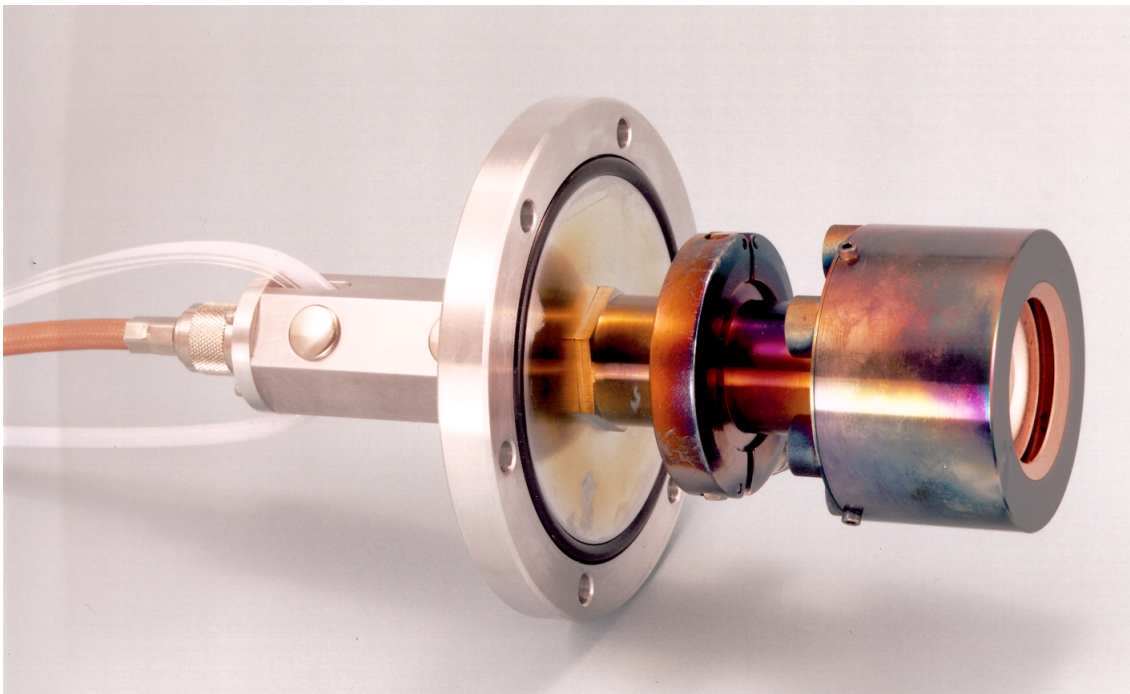

**Plasma Surface Engineering Corporation**  
**1662 Los Altos Road**  
**San Diego, CA 92109**  
**service@msi-pse.com**

**TABLE OF CONTENTS**

	<b><u>Page No.</u></b>
<b>1.0 OVERVIEW</b>	1
<b>2.0 SPECIFICATIONS</b>	
2.1 <u>Selecting The Correct Target Mounting Method</u>	1
2.2 <u>Target Thickness</u>	2
2.3 <u>Magnetic Field Strength</u>	3
2.4 <u>Pressure Range</u>	3
2.5 <u>Ultimate Pressure</u>	4
2.6 <u>Bakeout Temperature</u>	4
2.7 <u>Cooling Water</u>	4
2.8 <u>Argon Gas</u>	5
2.9 <u>Mounting Flanges</u>	5
2.10 <u>Power</u>	5
2.11 <u>Tapped Holes</u>	5
2.12 <u>Gas Fittings</u>	5
2.13 <u>Materials of Construction</u>	6
<b>3.0 INSTALLATION</b>	6
3.1 <u>Internal Cathodes</u>	7
3.1.1 Connecting Utilities	7
Water / Water Lines	7
Power	7
Sputtering Gas	7
3.1.2 Preparing to Make Utility Connections Using KF-40/1” Baseplate Feedthrough	9
3.1.3 Assembling The Cathode and KF-40/1” Baseplate Feedthrough Assembly	10
3.2 <u>External Cathodes</u>	10
3.3 <u>Electrical Power</u>	11
3.3.1 RF Power	11
3.3.1.1 Matching Network Installation	11
3.3.1.2 Simultaneous Operation of Multiple RF Sources	11
3.3.2 DC Power	12
3.3.3 Grounding Practices	12
3.4 <u>Cooling Water</u>	13
3.4.1 Water Lines	13
3.4.2 Pressure Regulation	13
3.4.3 Water Quality	13
3.5 <u>Sputtering Gas</u>	14

**DOCUMENT NO. 251010, Rev. B  
INSTALLATION, OPERATION AND  
USE OF POLARIS™ PLANAR  
MAGNETRON CATHODES  
6 FEBRUARY 2003**

	<u>Page No</u>
3.6	14
<u>Interlocks</u>	
3.6.1 Electrical	14
3.6.2 Water	14
3.6.3 Vacuum	15
3.6.4 Gas	15
<b>4.0 OPERATION</b>	<b>15</b>
4.1 <u>Pressure Range</u>	15
4.2 <u>Power Density</u>	15
4.3 <u>Cooling Water</u>	15
<b>5.0 TARGET MATERIALS</b>	<b>16</b>
5.1 <u>Target Bonding</u>	16
5.2 <u>Exchanging Clamped Targets</u>	17
5.3 <u>Exchanging Bonded and Directly Water Cooled Targets</u>	17
5.4 <u>Target Conditioning</u>	19
<b>6.0 MAINTENANCE</b>	<b>19</b>
6.1 <u>Insulators</u>	19
6.1.1 Bolt Insulators	20
6.1.2 Body Insulator (External Cathodes)	20
6.2 <u>O-rings</u>	20
6.3 <u>Cleaning the Ground Shield and Cathode Body</u>	21
6.4 <u>Magnet Module</u>	21
<b>7.0 PERFORMANCE ISSUES</b>	<b>21</b>
7.0 Film Thickness Distribution	21
7.1 Backscattering	22
<b>8.0 TECHNICAL REFERENCES</b>	<b>23</b>
8.1 <u>Recommended Reading</u>	23
<b>9.0 TROUBLESHOOTING</b>	<b>24</b>
9.1 Target Overheating	24
9.2 Plasma Will Not Ignite	24

**DOCUMENT NO. 251010, Rev. B**  
**INSTALLATION, OPERATION AND**  
**USE OF POLARIS™ PLANAR**  
**MAGNETRON CATHODES**  
**6 FEBRUARY 2003**

<b>10.0</b>	<b>APPENDIX</b>	25
10.1	<u>Parts Included With New Cathode</u>	25
10.2	<u>Spare Parts Included With New Cathode</u>	25
10.3	<u>Standard Magnet Module Field Profiles</u>	26
	10.3.1 2"/50mm Magnet Module	26
	10.3.2 3"/75mm Magnet Module	--
10.4	<u>Assembly Level Drawings</u>	32

**DOCUMENT NO. 251010, Rev. B  
INSTALLATION, OPERATION AND  
USE OF POLARIS™ PLANAR  
MAGNETRON CATHODES  
6 FEBRUARY 2003**

**1.0 OVERVIEW**

**Polaris** cathodes can be configured to meet specific processing requirements; consequently, some features of individual cathodes may be different than what is described in this manual. Examples of these variations include special mounting arrangements, magnet modules with unique field shapes and intensities, and completely custom designs.

Consequently, certain features (such as operating pressure range and maximum target thickness, for example) may vary from the values specified in this manual. However, basic utility and maintenance requirements will remain valid.

It is assumed that the user of these cathodes is familiar with the requirements of magnetron sputtering. Issues such as ensuring proper gas flow across the target surface, the need for a properly designed vacuum pumping system, design and installation of user supplied ground shields and other basic items which affect the performance of the magnetron cathode which are not addressed in this manual.

There are a number of good texts which address many of the processing issues relevant to magnetron sputtering. Some of these are identified in Section 7.0 Technical References.

**We are always glad to assist in any way possible if you need assistance in these areas. Please contact us at any time with your questions.**

**TEL/FAX: (858) 483-3223  
EMAIL: service@msi-pse.com**

**2.0 SPECIFICATIONS**

**2.1 Selecting the Correct Target Mounting Method**

It's certainly possible to clamp a 0.25" thick target to the 0.060" thick backing plate provided with the cathode and commence sputtering. What's the problem? No target bonding expense is incurred, the target cannot burn through and spring a water leak and everybody knows intuitively using thicker targets is better, by definition. Plus, it looks good in the sales brochure!

The trade-offs in the above example are a narrower operating pressure range and poor thermal conductivity (hence lower rates of deposition). The additional target life (measured in KWHr's) when using a 0.25" thick target compared to 0.125" - 0.1875" is extremely low and the target can cost twice as much. Why? The narrower and more steeply pitched the magnetic field lines are at the top of a new target (the region that defines the erosion area), the lower the ultimate target utilization. The attached finite element analysis model illustrates the point.

The limits described above are not unique to **Polaris** cathodes. The "laws of physics" apply to every competing design.

The real question then, is what pragmatic decision should be made? High power, high rate reactive TiN films should be grown using directly water cooled (no backing plate) 0.25" thick Ti targets. 0.125" - 0.1875" thick ZnO, I-T-O and similar targets should be bonded to the backing plate to minimize insulating film and "whisker" growth caused by hot spots (poor thermal conductivity). 0.125" thick copper targets can be clamped to the backing plate and run at extremely high power levels (2KW) without target surface melting and other problems.

**DOCUMENT NO. 251010, Rev. B  
 INSTALLATION, OPERATION AND  
 USE OF POLARIST™ PLANAR  
 MAGNETRON CATHODES  
 6 FEBRUARY 2003**

These are research cathodes, therefore, by implication, it's impossible to anticipate and document each possible application. Users do clamp brittle dielectric targets, but run them at extremely low power levels, keep an eye on the water pressure and accept the risk of cracking the target to save the bonding expense. The deposited films are usually very thin, therefore thermal problems are irrelevant because the target never gets hot enough to matter.

Clearly, target quality, actual application and user experience play a significant role in deciding the best approach.

**2.2 Target Thickness**

Cathodes are supplied with a 0.060" (1.6mm) thick backing plate as standard. Optimal performance (widest pressure range, best target utilization and cheapest targets) is achieved when a combined backing plate/target thickness of 0.1875" (4.7mm) is used. The magnet array has been optimized for this situation, as shown. Consequently, 0.125" (3.18mm) thick targets are recommended. The use of 0.25" (6.3mm) targets is only recommended when using directly cooled targets.

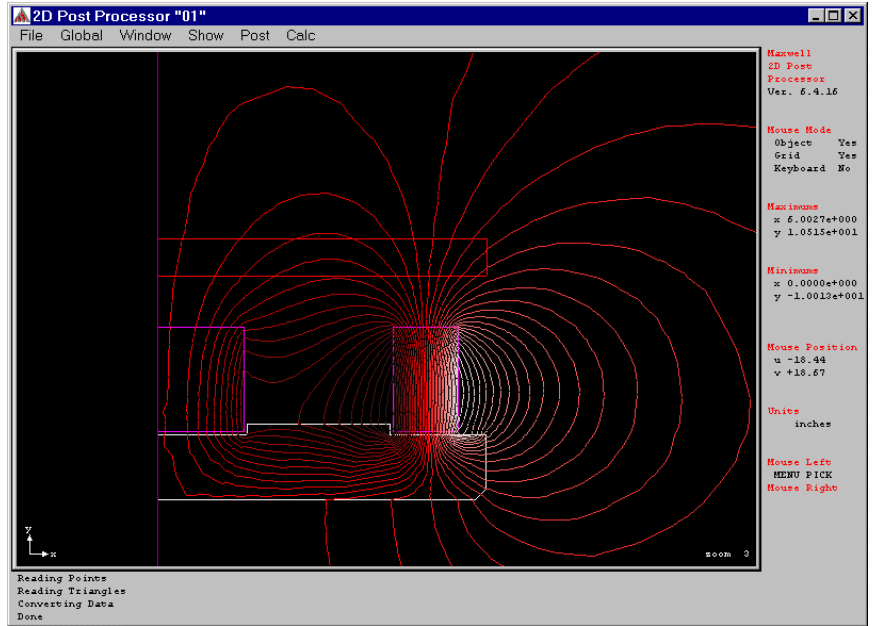

**Non-Permeable Materials**

Clamped or bonded (with backing plate):	0.125" to 0.1875"
Directly cooled solid targets (no backing plate)	0.1875" to 0.250"

**Permeable Materials (Using magnet module for magnetic materials)**

Co 62.5% Ni 7.5% Cr 30% (Wt%)	0.100"
Cobalt:	0.080"
Nickel:	0.100"
Iron:	0.060"

### **2.3 Magnetic Field Strength (Typical Values)**

Field profiles for all standard magnet modules (for non-permeable materials) are included in the Appendix.

It's a good idea, if possible, to measure the magnet module field strength at the center and edge (both perpendicular and parallel fields) on receipt **before** the cathode is used. Log the values recorded on the appropriate field profiles in the Appendix for future reference.

Materials Science uses a Lake Shore Cryotronics Model 460 3 channel gaussmeter calibrated and traceable to NIST (National Institute of Standards and Technology) reference standards.

Measured values are sensitive to the probe design plus the orientation and positioning of the probe when taking measurements. It's possible for two different individuals using different gaussmeters and probes to record values which vary by several hundred gauss for the same magnet module. Profiling the field strength (and establishing a known baseline using your own instrument) of the magnet module on receipt eliminates any potential confusion caused by this difference when attempting to diagnose potential degradation of magnet modules.

Suspected degradation in the magnet module should then be compared against these recorded values.

It is important that a **uniform** magnetic field is maintained throughout the target racetrack area. Significant variations between any two points on the same radius can cause the target to be eroded at a faster rate in the areas of higher field strength, resulting in poor target utilization and non-uniform films. Damage to the magnet assembly is the **only** reason this problem will occur.

**Overheating of the magnet module is almost always the reason for degraded magnet module performance. Dropping the magnet module can also cause shifts in or loss of field strength.**

See the Appendix for horizontal and vertical magnetic field values measured at target surface of various thickness non-magnetic targets.

The magnetic field should be uniform within +/- 5% between any two points on the same diameter within the erosion area.

### **2.4 Pressure Range**

**High End:** Approximately 1 Torr (Efficient magnetron sputtering occurs at pressures of  $3 \times 10^{-2}$  Torr argon pressure or less).

**Low End:** A plasma can be ignited and sputtering sustained at pressures of approximately  $5 \times 10^{-4}$  Torr argon pressure using any combination of target and backing plate thickness up to 0.375" thick for non-magnetic targets. **Stable operation is dependent upon having a pumping system with sufficient gas throughput capacity and mass flow controllers capable of operating in the desired region.**

**DOCUMENT NO. 251010, Rev. B  
INSTALLATION, OPERATION AND  
USE OF POLARIST™ PLANAR  
MAGNETRON CATHODES  
6 FEBRUARY 2003**

**2.5 Ultimate Pressure**

A base pressure of  $5 \times 10^{-9}$  Torr can be achieved in a well constructed and maintained vacuum system with cathodes installed.

**2.6 Bakeout Temperature**

With cooling water flowing:            20° to 180° C            (limited only by ability to keep cathode cool)

No cooling water flowing:            20° to 50° C

⇒ **Note:** Ion sources, heaters, filaments and other devices can cause significant heating of the cathode even while it is turned off. It's a good practice to leave the cooling water running at all times the chamber is under vacuum and in use to protect against inadvertent overheating of the magnet module and temperature sensitive parts.

**2.7 Cooling Water**

Inlet temperature:            Room temperature recommended. The temperature of chilled water systems should be regulated so that the dewpoint is never reached..

Exit temperature:            50 degrees C **maximum**

**Flow:**            Approximately 1.75 gallons per minute maximum @ 30psig inlet pressure, 5 psig exit pressure using 80" long,  $\frac{3}{16}$ " ID water lines and specified water fittings with no internal flow restrictions.

Note: A minimum flow rate of approximately 0.50 gpm should be established to prevent thermal damage to the magnet module. Practical **maximum** flow rates are established by the ductility of target materials and/or backing plates (see below).

Example: 2KW is applied to a 0.125" thick Cu target clamped to a 0.060" thick Cu backing plate. Inlet water temperature supplied by a closed-loop water recirculator cycles between 58° F - 70° F @ 30 psig inlet pressure - no back pressure. Water flow is 1.75 gpm and exit water temperature is 78° F in a steady state condition.

**Water Pressure:**            20 psig (material dependent - many metals and structurally strong materials can take up to 70 psig)

**PH Level:**            Range of 6 to 8

**Resistance:**            Greater than or equal to 50K ohms (relative to true earth, not signal ground)

**DOCUMENT NO. 251010, Rev. B  
INSTALLATION, OPERATION AND  
USE OF POLARIS™ PLANAR  
MAGNETRON CATHODES  
6 FEBRUARY 2003**

**Water Fittings:**

Two (2) each brass Parker P/N 68P-4-2  $\frac{1}{8}$ " NPT to  $\frac{1}{4}$ " or 6 mm OD plastic tube compression fitting.

Whenever the water fittings are reinstalled or replaced, wrap a few turns of teflon tape around the threads to help ensure a leak-free seal. The acetyl plastic sleeves (ferrules) may be reused multiple times on the same tubing before replacement is necessary.

**2.8 Argon Gas**

High purity (at least 99.995). Depending upon the gas throughput capability of the vacuum system, 2-3 sccm, when injected through the cathode, is sufficient to sustain a plasma discharge. Flow rates of up to 50 sccm can be injected through the cathode. Flow rates which exceed the gas throughput capacity of the system can raise the pressure within the dark space region too high, resulting in arcing and sputtering of the cathode and ground shield.

**2.9 Mounting Flanges**

**Internal:** KF 40, 2.75 OD CF flange with rotatable receiver and through holes or 1" baseplate feedthrough. Custom feedthrough tubes available.

**External:** O-Ring Seal per installation drawing.

**2.10 Power**

**Polaris** cathodes are suitable for use with either RF or DC power without modification. An M3 x 6 socket head cap screw is used to secure the power conductor to the cathode body.

**2.11 Tapped Holes**

Tapped holes are fitted with helicoil inserts and those exposed to vacuum are vented.

**2.12 Gas Fittings**

(Internal Mount Cathodes Only)

Cathode Body Gas Fitting: Swagelok  $\frac{1}{8}$ " OD

Gas Line Union: Swagelok  $\frac{1}{8}$ " OD

**DOCUMENT NO. 251010, Rev. B  
INSTALLATION, OPERATION AND  
USE OF POLARIS™ PLANAR  
MAGNETRON CATHODES  
6 FEBRUARY 2003**

**2.13 Materials of Construction**

<b>Cathode Body</b>	- C110 Copper
<b>Clamping Ring</b>	- AISI 304 stainless steel
<b>Backing Plate</b>	- Copper (standard) or other materials upon request
<b>Insulators</b>	- Virgin Electrical Grade Teflon
<b>O-rings</b>	- Viton
<b>Threaded Fasteners</b>	- Metric, chemically cleaned AISI 316 or 18-8 stainless steel. Fasteners used in blind tapped holes exposed to vacuum are vented.
<b>Magnet Assembly</b>	- 35MGOe NdFeB magnet array encapsulated in dense, durable epoxy resin
<b>Magnet Plate</b>	- AISI 416 stainless steel
<b>Magnet Cover</b>	- Brass
<b>Water Fittings</b>	- Brass, with acetal compression sleeves
<b>Water Lines</b>	- Teflon TFE or Polypropylene
<b>Gas Injection Line</b>	- Teflon PFA
<b>Gas Injection Fittings</b>	- AISI 316 stainless steel

(Internal Cathodes Only)

<b>Ground Shield Assembly</b>	- AISI 304 stainless steel
<b>Atmospheric Housing/Mounting Flange</b>	- AISI 304 stainless steel

**3.0 INSTALLATION**

***Notes:***

Always use either powder free plastic gloves or lint free cloth gloves when handling cathode.

⇒ **NEVER** lubricate threaded hardware as the lubricant **inevitably** is deposited on the substrate. Throw away fasteners and use new ones each time. The native oxide on the threads which prevents galling is broken when a new threaded connection is made. Reused fasteners almost always seize and gall, often resulting in expensive repairs and rework.

Always leak check the cathode after shipping, installation and exchange of bonded or solid targets.

Take care not to damage polished sealing surfaces. Minor scratches may be buffed out using Scotchbrite or fine-grit emory paper, but deep gouges and scratches usually require the surface to be re-machined.

Always check the cathode for resistance relative to chamber and true earth ground after installation. Resistance should be equal to or greater than 50K ohms with cooling water present. An open circuit should be indicated when water is absent.

⇒ **NEVER USE METAL TUBING BETWEEN THE SPUTTERING GAS INLET CONNECTION ON THE CATHODE BODY AND THE TUBING UNION PROVIDED!!!! THE TEFLON PFA TUBING PROVIDED HAS AN EXTREMELY HIGH DIELECTRIC VALUE AND IS USED AS AN INSULATOR.**

**DOCUMENT NO. 251010, Rev. B  
INSTALLATION, OPERATION AND  
USE OF POLARIS™ PLANAR  
MAGNETRON CATHODES  
6 FEBRUARY 2003**

**3.1 Internal Cathodes**

The atmospheric housing on internal cathodes usually consists of a KF-40 or 2.75 CF transition housing. This housing must first be removed to make the water, power and gas connections at the cathode body.

**3.1.1 Connecting Utilities**

(See Figures on Following Page)

***Water/Water Lines***

Wrap a few turns of teflon tape around the NPT threads of the water fittings, turn finger tight, then use a wrench on the hex flat to turn approximately another  $\frac{1}{2}$  turn, making the seal water tight.

Use at least a 60" (153mm) length of  $\frac{1}{4}$ " or 6mm OD Teflon TFE (preferred because it is available with larger inside diameters for maximum water flow) or polypropylene tubing for each water line. Make sure that both ends of each tube have been cut flush. Insert tube end until it bottoms out against the fitting, then turn the knurled hex nut finger tight. Then use a wrench to make one complete turn (about 2 complete turns for 6 mm OD tubing) after finger tightening. The water line should not pull out of the fitting when tugged on.

Slide the 9/16" OD Teflon TFE sleeves provided with the cathode over the water fittings when done. The sleeves act as protective insulators, preventing the possibility of the water fittings shorting to ground. It is essential that they are always in place.

***Power***

*(KF-40/1" Baseplate Feedthrough)*

Remove the protective plug (Item 4) from the feedthrough threaded aluminum housing. Use a flat blade screwdriver to loosen the power conductor from the ***female HN connector***.

*(All Internal Cathodes)*

Connect the ring terminal to the cathode body using the M3 socket head cap screw provided. Be certain that the teflon sleeve (protects against abrasion) is pushed over the power conductor when done.

**DOCUMENT NO. 251010, Rev. B  
INSTALLATION, OPERATION AND  
USE OF POLARIS™ PLANAR  
MAGNETRON CATHODES  
6 FEBRUARY 2003**

***Sputtering Gas***

The gas fitting has an o-ring face seal. Attach the fitting to the port marked “G” and finger tighten the fitting until metal to metal contact is made. The tubing connection is made using a 1/8” Swagelok fitting.

Use 1/8” OD tubing to connect between the Swagelok gas fitting on the cathode body and the Swagelok union.. Attach the union after the gas line has been fed through the feedthrough assembly. Alternatively, a gas line long enough to connect directly to the metering valve or mass flow controller may be used, eliminating the need for the union.

**Notes:**

- Tubing that is oval, that will not easily fit through the fitting nuts, ferrules and bodies should not be used.
- Surface finish is very important to proper sealing. Tubing with any kind of depression, scratch, raised portion or other surface defect will be difficult to seal.
- Insert tubing into Swagelok gas fitting. Make sure that the tubing face has been cut flat and smooth (not diagonally across the tube or ragged) so that the tubing face rests firmly on the shoulder of the fitting and that the nut is finger-tight.

**Tightening Instructions:**

- Never turn fitting body. Instead hold fitting body and turn nut.
- Hold the fitting body steady using the wrench flat on the fitting body and tighten the nut 1¼ turns.

**The gas connection can be disconnected and reused many times.  
To retighten:**

- Insert tubing with pre-swaged ferrules into fitting body until the front ferrule is fully seated.
- Tighten nut by hand, then rotate nut to the original position with a wrench as noted above. An increase in resistance will be encountered at the original position. Tighten **very slightly** beyond this point.

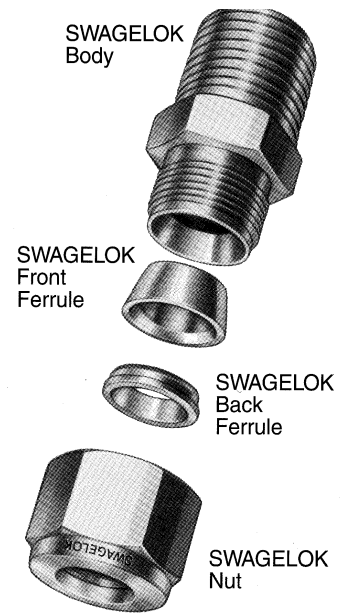

**CORRECT ORIENTATION OF  
FRONT AND BACK FERRULES**

**DOCUMENT NO. 251010, Rev. B**  
**INSTALLATION, OPERATION AND**  
**USE OF POLARIS™ PLANAR**  
**MAGNETRON CATHODES**  
**6 FEBRUARY 2003**

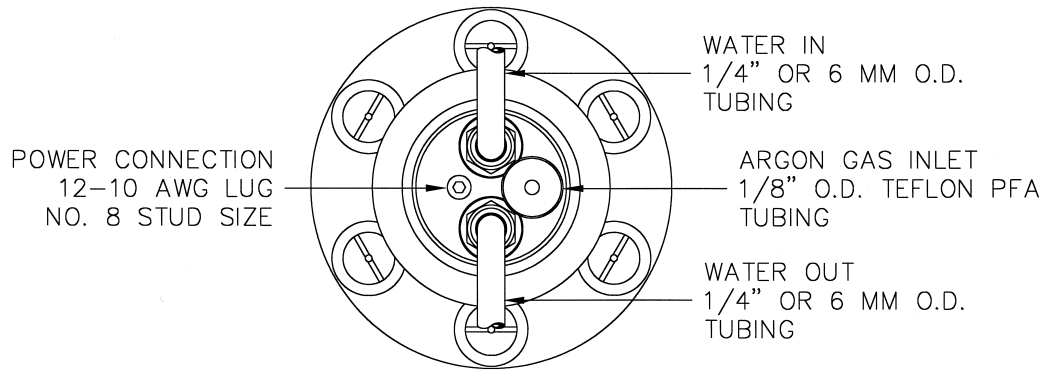

**UTILITY CONNECTIONS AS SEEN THROUGH INSIDE OF KF-40 FLANGE**

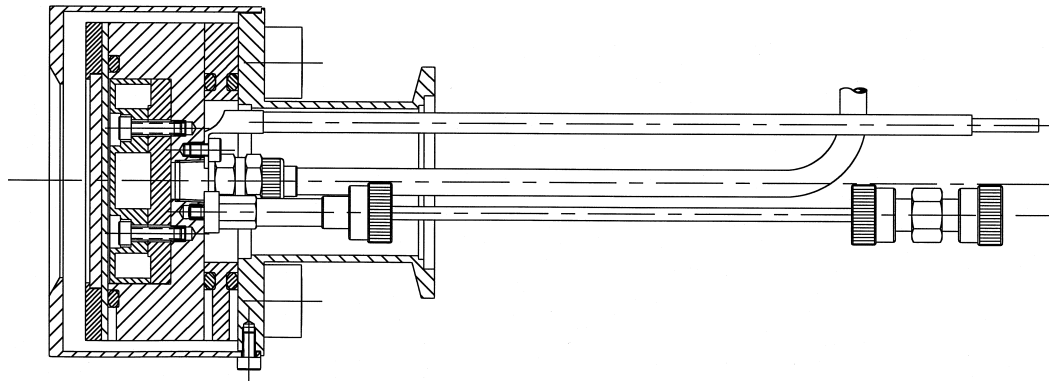

**SIDE VIEW OF UTILITY CONNECTIONS**

**DOCUMENT NO. 251010, Rev. B  
 INSTALLATION, OPERATION AND  
 USE OF POLARIST™ PLANAR  
 MAGNETRON CATHODES  
 6 FEBRUARY 2003**

**3.1.2 Preparing to Make Utility Connections Using KF-40/1" Baseplate Feedthrough:**  
 (Refer to Illustrations on This and Preceding Page)

- Remove Ground Shield by unfastening retaining screws
- Remove Bolt Insulator Caps
- Unfasten socket head cap screws within Bolt Insulators and remove Bolt Insulator, screw and washer as assemblies.
- The Mount Flange Housing may now be removed, exposing the utility connections shown on the previous page:

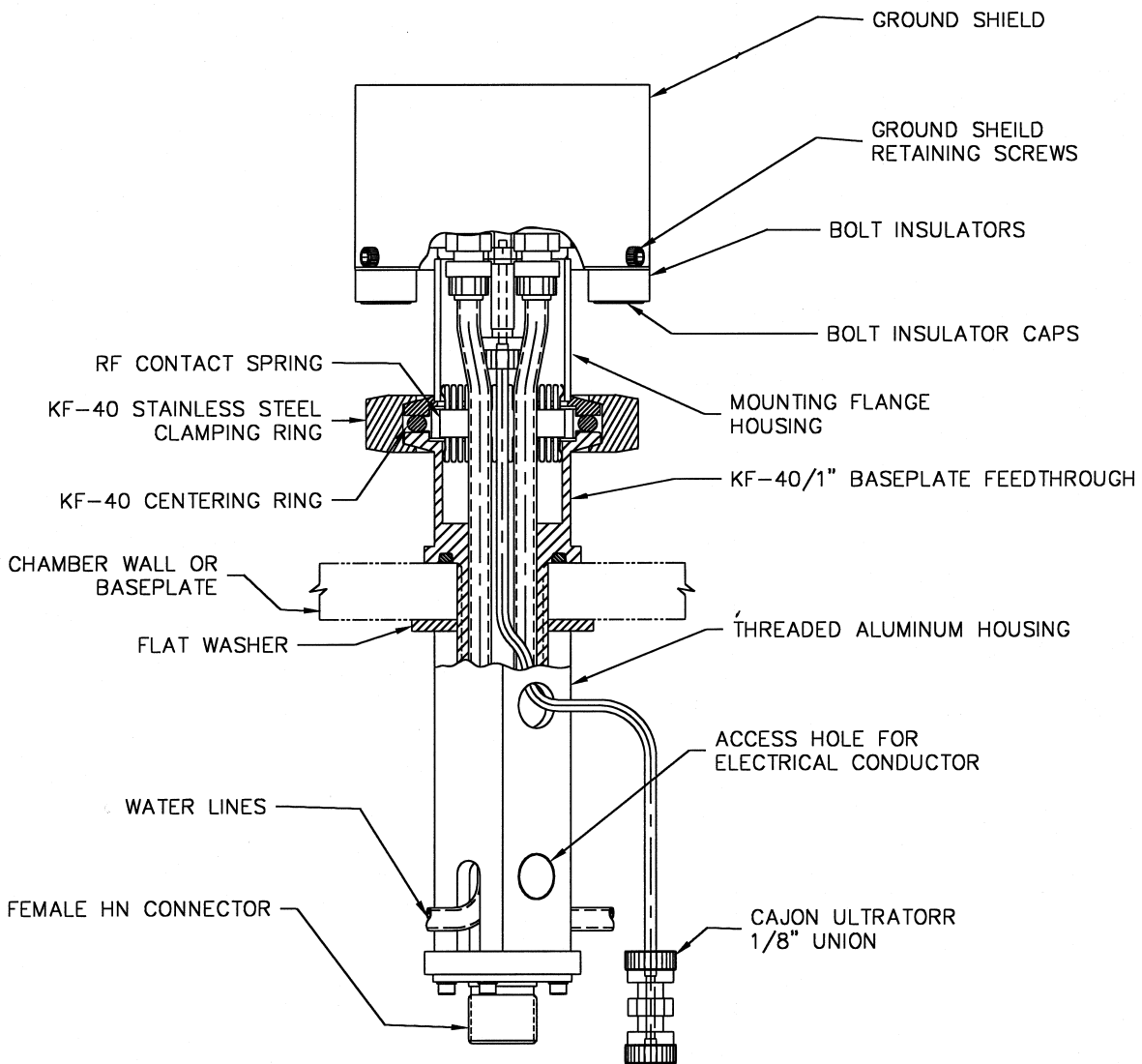

**DOCUMENT NO. 251010, Rev. B  
INSTALLATION, OPERATION AND  
USE OF POLARIS™ PLANAR  
MAGNETRON CATHODES  
6 FEBRUARY 2003**

**3.1.3 Assembling the Cathode and Feedthrough Assembly**

- Insert the 1” feedthrough into the hole in the chamber wall (baseplate) and assemble using washer and nut to make the vacuum seal. A polished surface (32 RMS) is required on the vacuum chamber inner wall for the o-ring seal.
  - Slide the water lines, gas line and power conductor through the teflon body insulator (Item 6), transition housing, KF-40 centering ring and RF contact spring.
  - Reassemble the cathode assembly in the reverse order noted above for disassembly.
  - Feed the water lines, power conductor and gas line through the KF-40 to 1” baseplate feedthrough.
  - Loosen the screws (if necessary for clearance) holding the female HN connector to the threaded aluminum housing and feed the water lines through the slotted holes in the housing. Tighten the screws again.
  - Feed the sputter gas line through the hole closest to the KF-40 flange, then attach the Ultra-Torr union to the end of the gas line (or eliminate the union and use a gas line long enough to connect to the metering valve or mass flow controller).
  - Assemble the feedthrough to the cathode using the stainless steel KF-40 clamp provided. This clamp is made completely of stainless steel and is completely high vacuum compatible. Do not substitute other clamps as the likelihood of contaminating the vacuum system is very high.
- ⇒ **Lightly lubricate the thread on the KF-40 clamp with a vacuum compatible lubricant such as molybdenum disulfide or boron nitride to prevent galling of the threads. Cover the nut and thread with aluminum foil to prevent deposition on these pieces.**
- Thread the aluminum housing onto the KF-40 feedthrough and insert the end of the power conductor into the receptacle on the HN connector and tighten the screw through the access hole in the aluminum housing. Replace the hole plug when done. If the center conductor is too long, simply cut the tinned end off and re-tin prior to inserting into the HN receptacle.

**3.2 External Cathodes**

A polished o-ring sealing surface (32 RMS) must be provided surrounding the cathode cutout in the vacuum chamber. The cathode must be firmly and uniformly clamped to the chamber wall to ensure leak free pumpdown of the system from atmosphere.

The installation arrangement should include a method of precisely repositioning the cathode and ground shield after they have been removed to maintain specified, uniform dark space gap. Failure to do so will likely result in arcing, pitting of the cathode body and ground shield, as well as coating of and damage to the insulator.

### **3.3 Electrical Power**

#### **3.3.1 RF Power**

⇒ **RF POWER SUPPLIES MUST BE COUPLED TO THE CATHODE THROUGH A MATCHING NETWORK.**

⇒ **Note:** RF power connections should only be made by persons familiar with and fully qualified to perform such work. **RF POWER LEAKAGE CAN CAUSE SERIOUS INJURY OR DEATH.**

External cathodes should be fully covered and shielded by a protective, INTERLOCKED enclosure. Radiated power levels should be checked by qualified personnel prior to routine operation of the system.

##### **3.3.1.1 Matching Network Installation**

The RF power supply may be remotely located. Use only properly rated coaxial cable to connect the power supply to the matching network. Do not coil the cable.

Flexible coaxial cables are prone to serious overheating. When making your own cables, keep the distance between the matching network and the cathode as short as possible (recommend no longer than 3 feet), exercise extreme caution and consult an RF power expert. The impedance can create large circulating currents on this interconnect cable. Any increase in circulating current greatly increases the losses in the cable.

In light of this fact, a Teflon dielectric cable (RG 393 is recommended) should be used because Teflon has a more favorable thermal characteristic than other cable materials. The Teflon will minimize migration of the center conductor due to overheating, thus reducing the probability of the center conductor shorting to the outer sheath.

A key consideration in the placement of the matching network is the return current from the matching network/chamber system. If an RF cable is used to connect the tuner to the chamber, all the circulating return currents will be on the outer sheath of the cable.

Good ground connections which meet local electrical codes are essential. The matching network should be grounded (usually through its AC power connector). Additionally, the matching network should have a good RF ground. Good RF grounding is aided by mounting the matching network as close as possible to the vacuum feedthrough. Improper grounding of the matching network will result in radio frequency interference (RFI). RFI causes instrumentation and computers to operate erratically, solenoid controlled devices such as valves to “chatter” and other problems.

Ground planes within the chamber must be kept equidistant from the cathode.

##### **3.3.1.2 Simultaneous Operation of Multiple RF Sources**

When two or more RF power sources (i.e. two cathodes or one cathode with RF biased substrate) are run simultaneously, the phasing of the RF generators must be controlled. Slaving multiple RF generators to the same crystal oscillator (“common oscillator”) allows the control of the phase relationship of the generators within the plasma.

**DOCUMENT NO. 251010, Rev. B  
INSTALLATION, OPERATION AND  
USE OF POLARIST™ PLANAR  
MAGNETRON CATHODES  
6 FEBRUARY 2003**

The phasing between generators is controlled through the use of a calibrated, variable line delay (“phase shifter”), usually sold as an optional device by most power supply manufacturers. Ensure that this device is included when power supplies are purchased.

A matching network must be provided for **each** device connected to an RF generator.

### **3.3.2 DC Power**

An M3 tapped hole is provided for connection of DC power. Simply connect the output of the plasma power supply to this connector using a properly rated cable with a 12-10 AWG crimping lug, No. 8 stud size. Use a ring terminal to prevent the high voltage cable from detaching itself from the cathode during operation. The RF feedthrough arrangement is also suitable for DC power.

Power supplies purposefully designed for magnetron sputtering should be used. These supplies have arc suppression circuitry, protect against RF transient voltage spikes (several KV) that magnetron plasmas can produce and allow output power to be regulated in constant voltage, constant current or constant power modes.

The power supply should operate in a constant current mode in a range of at least 300 - 750 volts. Typical magnetron sputtering occurs at 200 - 1000 volts. The surface area of the cathode will determine the current requirements, which can be as small as 0.5 amps for 2” cathodes.

An RF filter should be put on the DC input to the chamber when RF bias is applied to the substrate or an RF cathode is used in addition to the DC powered cathode. 13.56 MHz will cause serious problems for most unfiltered DC power supplies. However, if the DC power supply is pulsed, care must be taken when selecting the RF filter to be used. If the inductance of the filter is too large, it may interfere with the pulsing of the DC supply. Consult the power supply user’s manual and a qualified RF power expert when applying this sort of biasing.

### **3.3.3 Grounding Practices**

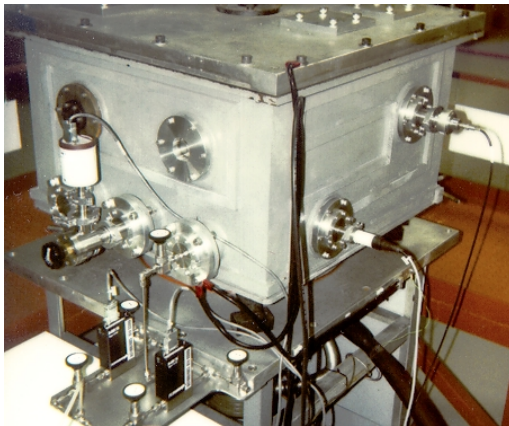

**VIEW OF TYPICAL VACUUM CHAMBER SHOWING TOP PLATE, CHAMBER AND FLANGE(S) GROUNDED (BLACK CABLES) TO TRUE EARTH GROUND**

The importance of true earth grounding for basic safety and equipment protection reasons cannot be overstated. If the system does not have it, make certain this situation is immediately rectified. Do not confuse signal ground with true earth ground. Signal ground does not ensure safety. Users are referred to the referenced documents on this subject in 8.0 Technical Documents.

### **3.4 Cooling Water**

**DOCUMENT NO. 251010, Rev. B  
INSTALLATION, OPERATION AND  
USE OF POLARIS™ PLANAR  
MAGNETRON CATHODES  
6 FEBRUARY 2003**

**3.4.1 Water Lines**

Electrical power **is** transmitted through the cooling water circuit. Ensuring that the electrical resistivity of the water lines is sufficiently high prevents this from occurring. Refer to the section on cathode specifications for the correct resistivity values.

⇒ Do not use water lines shorter than 60" (153 mm) for either the inlet and exit lines. Teflon TFE (recommended) or polypropylene water lines should be used. Use water lines with the maximum clear inner diameter ( $\frac{3}{16}$ " recommended) to ensure proper water flow. Remember that the longer the water line, the greater the conductive loss (flow). **NEVER** use copper tubing or any metallic conductor. **DO NOT USE THE WATER LINES AS THE POWER CONNECTION.** Carbon filled (black) tubing is electrically conductive and must not be used.

The inlet line should be located below the exhaust line on horizontally mounted cathodes.

**3.4.2 Pressure Regulation**

Use a water flow regulator to control internal pressures within the cathode. It is generally recommended that the internal pressure does not exceed 20 psig when using brittle targets (though many metal targets can take up to 70 psig). Greater internal pressurization of the cathode causes the backing plate to warp and targets to crack, and water leakage past the backing plate o-ring seal can occur under extreme conditions (more than 100 psig).

**3.4.3 Water Quality**

**DO NOT** use de-ionized or distilled water, as they will attack and corrode the copper body as well as the magnet plate. Conditioned city water in recirculating water systems is best. Anti-corrosion agents, such as ethylene glycol with additives ("Dowtherm") should be used. Refer to the specification section for proper pH, temperature and other requirements. Avoid the use of algaecides or other water treatments. Galvanic corrosion will occur if materials other than brass, copper, elastomers and PTFE are present in the cooling water system.

### **3.5 Sputtering Gas**

Sputtering gas (typically argon or an argon gas mixture) is admitted through the cathode body and symmetrically distributed through the dark space region, allowing for uniform diffusion of the gas through the dark space gap and across the target surface.

This feature is important, compared to simply introducing gas directly into the chamber or through a separate gas fitting, for several reasons:

- Allows lower background pressures for higher purity films.
- Eliminates localized high pressure in one region of the target which results in premature burnthrough of the target and disuniform film thickness on the substrate.
- Because no gas fittings, shields or manifolds are provided external to the cathode itself, the need for an additional feedthrough and gas lines within the vacuum chamber is eliminated.
- External gas fittings and injection shields usually are at ground potential and frequently glow red-hot. Target material is also deposited on these surfaces, causing process and maintenance problems.
- Much lower gas consumption compared to filling the entire chamber.
- Ensures that sputtering gas depletion on the target surface does not occur - an adequate supply of argon gas is always present to maintain desired sputtering rates.
- Allows the use of DC sputtering in the growth of reactively deposited films by maintaining a buffer region that mitigates against the formation of insulating films on the target surface when target material removal rates are also high enough.

### **3.6 Interlocks**

#### **3.6.1 Electrical**

External cathodes should always be covered by a protective enclosure equipped with magnetic breaks or microswitches which will immediately disable the cathode power supply when the cover is removed.

The enclosure should be designed so that it must be properly installed and fully enclose and shield the cathode before the interlock is enabled to protect against careless installation.

#### **3.6.2 Water**

Water flow sensors must be installed and interlocked to the power supply. This prevents damage to the cathode caused by inadequate or no cooling water flow. Overheating the magnet module will weaken or destroy the magnetic field.

Flow meters and metering valves should be installed on the inlet side of the cathode.

Flow sensors should be installed on the outlet side of the cathode. Switches which allow visual inspection and require positive water flow to induce a voltage and maintain relay closure are strongly suggested. Some water switches can fail closed and still indicate the presence of cooling water even when it is absent.

**DOCUMENT NO. 251010, Rev. B  
INSTALLATION, OPERATION AND  
USE OF POLARIS™ PLANAR  
MAGNETRON CATHODES  
6 FEBRUARY 2003**

⇒ Each cathode should be provided with an independent water circuit as described above. Never provide cooling water to the cathodes in series. This practice reduces water flow, increases backpressure within the cooling circuit and could result in overheating of the cathodes.

### **3.6.3 Vacuum**

To further insure against process failures, a chamber vacuum gauge should be interlocked to the cathode power supply, which will prevent the power supply output from being turned on unless the chamber is within the required pressure range.

### **3.6.4 Gas**

The flow of sputtering gas may also be interlocked to the power supply when using mass flow controllers in order to maintain the sputtering environment within the desired range.

## **4.0 OPERATION**

### **4.1 Pressure Range**

Polaris cathodes operate at pressures from approximately 1 Torr to  $3 \times 10^{-4}$  Torr argon pressure.

### **4.2 Power Density**

(Also see Section 5.0 Target Materials)

Power supplies rated at 500 - 2500 watts are recommended, although power supplies with higher ratings may also be used provided they will be stable at the lowest power level desired. This value is usually stated by the power supply manufacturer as a percentage of the maximum rated output parameters.

The better the thermal conductivity of the material, quality of fabrication technique and bond quality, the higher the maximum power density.

Maximum allowable power densities are material dependent. The thermal characteristics of the target material, its sputter yield and whether the target is clamped (indirectly cooled), bonded to a backing plate or directly cooled all influence how much power can be applied to the target to achieve high rates.

### **4.3 Cooling Water**

It is important that cooling water be flowing through the cathode, with inlet and exit temperatures in the ranges given in the specifications section whenever the cathode and magnet assembly are subjected to heat. This would include normal operation of the cathode, as well as operation of nearby sources of heat within the vacuum chamber (such as heating elements, filaments, ion sources, etc.). Without cooling water flowing in these situations, the cathode will overheat and the magnetic field will be degraded or destroyed.

**DOCUMENT NO. 251010, Rev. B  
INSTALLATION, OPERATION AND  
USE OF POLARIS™ PLANAR  
MAGNETRON CATHODES  
6 FEBRUARY 2003**

**5.0 TARGET MATERIALS**

(Refer to Materials Science Specification No. 10000000)

Target materials should be as close to theoretical density as possible, particularly when high purity work is required. Low density targets are sources of contaminating gases, particularly in targets fabricated from powders by hot pressing, vacuum hot pressing and sintering. Oxygen, in particular is sorbed on the surface of the unprocessed powder and is virtually impossible to later eliminate. Vacuum casting, arc-melting and hot isostatically pressing (HIPing) are usually superior fabrication techniques. Poor target density also can result in low sputtering rates, premature target exhaustion, poor utilization, warping and cracking.

**5.1 TARGET BONDING**

Care must be taken not to contaminate the target material with the bonding agent.

The bonding material must be void free. Hot spots can develop on poorly bonded targets resulting in melting, spitting and even complete target delamination due to thermal fatigue.

Backing plates should be made from materials which most closely match the thermal expansion characteristics of the target. Specialty glasses, Sendust and certain magnetic alloys are examples of materials which may crack during the bonding process due to thermal expansion mismatch.

Epoxy bonds are emphatically not recommended! Epoxy bonding agents are brittle, have poor thermal transfer properties and are sources of organic contamination.

Metallic solder bonding, usually using indium, is preferred. Very often it is necessary to deposit adhesion layers on the backside of the target and bonding surface of the backing plate prior to making the solder bond.

*Yes, we know it costs additional money to have the targets bonded, but clamped targets have three point contact in the center of the target and simply cannot be as efficiently cooled. Life is full of compromises!*

Dielectrics and certain metals and alloys which are brittle and/or poor thermal conductors should always be bonded to a backing plate and directly cooled to avoid cracking and warping. Direct cooling allows much higher applied power densities, hence at least two times the sputter rate of indirectly cooled, clamped targets. Brittle materials should never be clamped to avoid fracturing the target.

**WHEN EXCHANGING TARGETS**

⇒ HIGH VOLTAGE CAN BE PRESENT EVEN WHEN POWER SUPPLIES HAVE BEEN TURNED OFF! ALWAYS GROUND THE CATHODE WITH A GROUNDING STICK PRIOR TO TOUCHING THE CATHODE FOR ANY REASON.

⇒ ALWAYS CHECK THE CATHODE BODY FOR RESISTANCE OF AT LEAST 50,000 OHMS RELATIVE TO A TRUE EARTH GROUND WHEN COOLING WATER IS FLOWING. AN OPEN CIRCUIT SHOULD BE INDICATED WHEN WATER IS ABSENT.

⇒ LET THE CATHODE COOL TO AMBIENT TEMPERATURE PRIOR TO TURNING OFF THE COOLING WATER SUPPLY.

**DOCUMENT NO. 251010, Rev. B  
INSTALLATION, OPERATION AND  
USE OF POLARIST™ PLANAR  
MAGNETRON CATHODES  
6 FEBRUARY 2003**

Target clamping bolts should not be over-tightened. Tighten the bolts in an alternating pattern to no more than 5 Newton-meters (44 Inch-pounds) maximum tightness. Set the torque rating of the wrench to a value of approximately one-half of this number, tighten all the bolts, then increase the setting several times until the recommended value is reached.

**5.2 Exchanging Clamped Targets**

Remove the ground shield assembly (internal cathodes only). Remove the bolts holding the clamping ring in place and set clamping ring aside.

**DO NOT** loosen or remove the screws which fasten the backing plate to the cathode body, otherwise the vacuum to water seal will be broken.

Replace target and reverse procedure. Be sure that the clamping ring is correct for the target thickness. Do not use targets which are too thin to be firmly clamped and **DO NOT USE SHIMS OR INSERTS TO TAKE UP SLACK**. This results in extremely poor thermal contact and inadequate cooling. Furthermore, mating surfaces which are not vacuum relieved act like virtual leaks and outgas - causing arcing.

Targets which are slightly thicker than the clamping ring is designed for may be used by substituting longer bolts. The bolts must be vented to prevent arcing and film contamination. This practice is **not recommended** as a routine procedure, only as an interim measure until a properly sized clamping ring is obtained.

**5.3 Exchanging Bonded and Directly Water Cooled Targets**

Drain the water from the cathode body and purge the water lines with nitrogen or dry, unlubricated compressed air prior to disassembling the cathode. **DO NOT USE AN UNREGULATED COMPRESSED AIR SUPPLY. DO NOT USE AIR PRESSURE WHICH EXCEEDS 20 PSIG MAXIMUM.**

Remove the adjustable ground shield assembly (internal cathodes only).

Remove the bolts and/or clamping bars holding the bonded target assembly to the cathode body. Be careful not to scratch or damage the polished o-ring sealing surface on the backing plate.

Inspect the o-ring for hardening, cracking, nicks or gouges and replace if necessary.

Replace target and reverse procedure.

⇒ **CAUTION:** Avoid removing or handling the magnet assembly. Physical shock can weaken the magnet assembly and damage to the protective epoxy coating can allow water to attack and degrade the rare earth magnets.

**DOCUMENT NO. 251010, Rev. B  
INSTALLATION, OPERATION AND  
USE OF POLARIS™ PLANAR  
MAGNETRON CATHODES  
6 FEBRUARY 2003**

**TARGET CLAMPED TO BACKING PLATE**

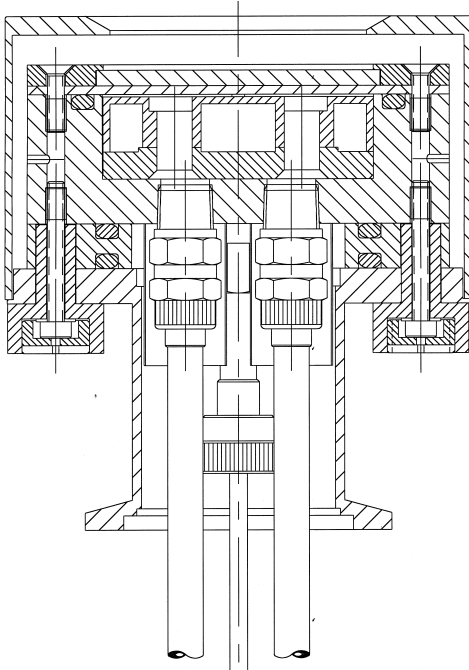

**TARGET BONDED TO BACKING PLATE**

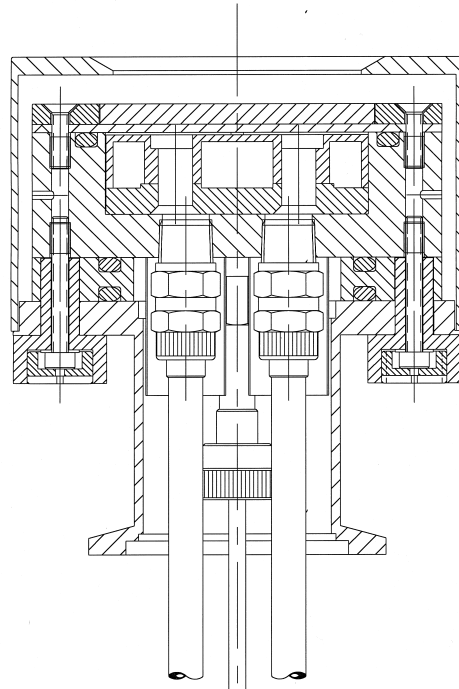
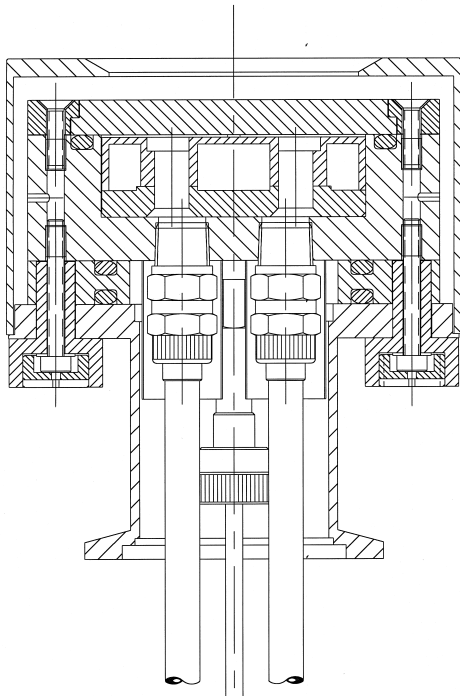

**DIRECTLY WATER COOLED TARGET  
(NO BACKING PLATE)**

**DOCUMENT NO. 251010, Rev. B  
INSTALLATION, OPERATION AND  
USE OF POLARIS™ PLANAR  
MAGNETRON CATHODES  
6 FEBRUARY 2003**

**5.4 Target Conditioning**

Magnetron cathodes are more likely to arc than other types of sputtering sources. This is due to the nature of the low voltage, high current power supplies required to drive the low impedance plasma discharge created by magnetron cathodes. An arc at full power caused by a small localized region of surface oxide can cause the entire discharge current to be momentarily focused on this spot, melting the target at the point of discharge. Therefore, it is important to first presputter (“condition”) targets to remove surface oxides and other contaminants.

When a new target has been installed in a cathode, or the system has been exposed to air for extended periods of time, arcing will likely occur.

To minimize this situation, close the cathode shutter, pump the system down below  $10^{-4}$  Torr and let the pressure stabilize, then raise the sputtering system pressure and apply low level power to the cathode.

Slowly increase power to the desired deposition density. Do not increase the power level until arcing is reduced at the present power level. This process should typically take about 30 to 60 seconds for most pure metals. A 5 minute ramp to the maximum allowable power density for other materials should be sufficient. Certain materials such as aluminum which form a tenacious oxide may take as long as 30 minutes to clean. The best way to establish what the correct conditioning period should be for various materials is to note how long it takes for the discharge current to fall to a constant value while controlling the voltage.

The plasma should be stable and no arcing should occur upon completion of the conditioning period. The shutter can now be opened. It is assumed that targets which have been properly fabricated are used and that they are installed in cathodes situated in well designed and maintained vacuum systems.

Target materials with poor density or which operate in poorly maintained systems may take much longer than this (up to 30 minutes) to condition.

Increasing system argon pressure will aid in conditioning targets with heavy oxide layers.

**These time periods are guidelines only!** Each user must establish the amount of time to properly condition targets empirically. There are no broadly applicable hard and fast rules.

**6.0 MAINTENANCE**

**6.1 Insulators**

The cathode insulators are fabricated from virgin electrical grade teflon because of its desirable characteristics such as high dielectric value, moderately low gas permeability, low outgassing rates, high operating temperature and good general resistance to chemical attack.

The primary drawback to the use of teflon is its propensity to cold flow, particularly when force is applied at higher temperatures. Insulators and o-rings may remain leak tight even after undergoing compression set until they are disturbed. Once disassembled, an insulator or o-ring which has taken a serious compression set cannot be reused.

Teflon is also soft and susceptible to physical damage such as gouging. Always handle all teflon parts carefully.

**DOCUMENT NO. 251010, Rev. B  
INSTALLATION, OPERATION AND  
USE OF POLARIST™ PLANAR  
MAGNETRON CATHODES  
6 FEBRUARY 2003**

Deposited material may be removed from the teflon insulators using a fine grit abrasive cloth or similar technique. Do not use solvents or grit or bead blasting.

**6.1.1 Bolt Insulators (Internal Cathodes)**

These insulators are an expendable item, but may be reused multiple times if cleaned and handled carefully.

Gas scattering causes the bolt insulators to become quickly coated with the target material. The bolt insulators have a vented, protective cap which prevents a conductive coating from covering the inside of the insulator and shorting the cathode. Failure to install the protective cap will result in shorting

Tighten the bolts in an alternating pattern to 1.30 to 1.36 Newton-meters (10 to 12 inch-pounds) maximum tightness. Set the torque rating of the wrench at a value of approximately one-half of this value, tighten all the bolts, then increase the setting several times until the recommended value is reached.

**6.1.2 Body Insulator (External Cathodes)**

Viton o-ring seals are soft and don't require much compression to obtain a good vacuum seal.

A loading force of 13 kg/cm<sup>2</sup> (14.7 pounds per linear inch - nominal atmospheric pressure) is sufficient to compress the o-ring(s) between the Teflon insulator, vacuum system wall and cathode body. As a practical matter, finger tightening the retaining bolts, then slightly tensioning them will make a leak tight seal without deforming the Teflon insulator.

**6.2 O-Rings**

Viton o-rings are used in all cathodes.

O-rings take a compression set and harden over time. It is a good practice to replace o-rings whenever degradation is suspected. Exposure to high temperature (above 150°C) and to various chemicals within the processing environment will accelerate degradation of the o-ring and determine the o-ring replacement schedule.

Never clean o-rings with solvents. Most commonly used organic solvents such as acetone will damage or degrade the polymer material. All will enter the surface and outgassing will remain high for a very long time.

Grease can usually be used without harm in unbaked vacuum systems where scratches in sealing surfaces, o-ring surfaces or dust would cause leaks otherwise, but Materials Science strongly discourages the use of grease on general principal. Use (sparingly!!!) only high quality, low vapor pressure (10<sup>-7</sup> Torr and below) hydrocarbon based vacuum greases like Apiezon L, Apiezon M, Dow Corning DC 976 and equivalent products when the decision to use grease has been made. Do not use silicone based grease such as Dow Corning DC 704. Once silicone is in a vacuum system it can never be removed.

Grease can cause gas bursts (and arcing) as gas escapes from the grease or from traps between the o-ring and mating surfaces, so the ideal practice is to use dry, unlubricated o-rings and to maintain good sealing surfaces to prevent film contamination and arcing. Furthermore, the presence of

**DOCUMENT NO. 251010, Rev. B  
INSTALLATION, OPERATION AND  
USE OF POLARIST™ PLANAR  
MAGNETRON CATHODES  
6 FEBRUARY 2003**

grease on an o-ring sealing surface interferes with the ability to locate surface anomalies (scratches, pits, gouges, etc.) that could cause gas or water leaks.

NEVER USE ANYTHING HARDER THAN WOOD TO REMOVE AN O-RING FROM ITS GROOVE. The use of harder materials and/or gouging into the groove at an angle will scratch the o-ring surface, potentially causing leaks. P/N 53385A48 "Orange Sticks" (Birch wood) are available from McMaster-Carr Supply Company.

### **6.3 Cleaning the Ground Shield and Cathode Body**

The ground shield may be cleaned as described below or by grit blasting. Grit blasting roughens the surface and reduces flaking of target material which could cause shorting or debris falling on the substrate.

All stainless steel parts such as clamping rings may be cleaned with fine abrasives, acids (such as HCl), or bases (such as NaOH). Chemical cleaning or light electropolishing are also acceptable techniques.

The water cavity of the cathode body should not require cleaning if a properly designed cooling system has been used. However, follow the cleaning instructions above if scale removal becomes necessary and take steps to prevent a reoccurrence of scale buildup. The copper may be polished using mild abrasives or Scotchbrite.

### **6.4 Magnet Module**

The magnet module requires no routine maintenance. Any scale buildup may be removed using a fine grit emery cloth. **Do not damage or penetrate the protective epoxy coating contained in the magnet assembly in any way. Do not subject the magnet assembly to physical shock as this is likely to shift the magnets, crack the epoxy (creating fissures) and warp or bow the brass cover.** NeFeB magnets are extremely susceptible to corrosion when exposed to water or air and will rapidly degrade - handle the magnet module with care to prevent this from occurring.

Ensure that the magnet module is properly reinstalled after removal. Modules have counterbored holes on the "top" side that act as a key to prevent the module from being installed upside down. The cathode will not function properly if the magnet module is not properly oriented.

## **7.0 PERFORMANCE ISSUES**

### **7.1 Film Thickness Distribution**

It is often incorrectly assumed that magnetron sputtering sources exhibit some kind of intrinsic distribution profile that can be assumed. Several factors strongly influence the physical distribution of actual film growth, including the atomic mass of the target material relative to both the argon and reactive gases, source-to-substrate distance and pressure. Transport of the sputtered material from the target is best and most predictable when pressures are lower and the source-to-substrate distance is shortest (assumed "line of sight" transport from the target to the substrate). Generally, these conditions are said to exist when the chamber pressure is approximately  $1.5 \times 10^{-3}$  torr or lower at a 1.75" to 4" source-to-substrate distance.

Materials Science has developed a thin film distribution analysis modeling program that can help in determining what initial conditions should be established as a starting point to achieve desired results. However, it should be noted that a prediction is just that, not a guarantee. System gas

**DOCUMENT NO. 251010, Rev. B  
INSTALLATION, OPERATION AND  
USE OF POLARIS™ PLANAR  
MAGNETRON CATHODES  
6 FEBRUARY 2003**

throughput capability, chamber and fixturing geometries and location of cathodes and substrates relative to each other and pumping ports can all strongly influence actual performance.

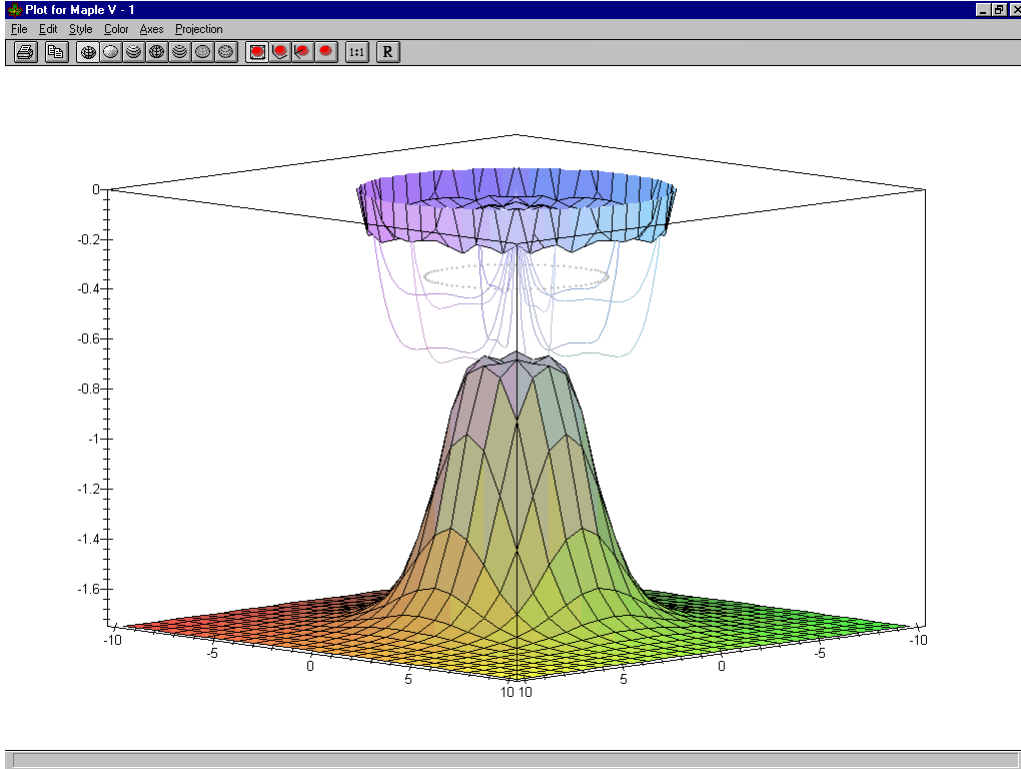

THIS IS A TYPICAL THIN FILM DISTRIBUTION MODEL. VARIABLES INCLUDE SOURCE-SUBSTRATE DISTANCE, TARGET AND SUBSTRATE SIZE, MOTION, ANGULARITY, ETC. THE MAGNETIC FIELD LINES ARE THOSE IMPORTED FROM A FEA MODELER AND CORRESPOND TO THE ACTUAL TARGET EROSION PATTERN, FROM WHICH THE DISTRIBUTION UNIFORMITY IS CALCULATED. THE AREA OF INTENSE PLASMA DISCHARGE IS INDICATED RELATIVE TO THE SUBSTRATE.

## **7.2 Backscattering**

Backscattering or redeposition of the target material can become significant when the mass of the argon gas exceeds that of the target material. The problem becomes greater when source-to-substrate distances increase. Sputtering aluminum in an argon plasma is the classic example of this phenomena.

**DOCUMENT NO. 251010, Rev. B  
INSTALLATION, OPERATION AND  
USE OF POLARIS™ PLANAR  
MAGNETRON CATHODES  
6 FEBRUARY 2003**

**8.0 TECHNICAL REFERENCES**

**8.1 Recommended Reading**

Leon I. Maissel and Reinhard Glang, Eds., Handbook of Thin Film Technology, McGraw-Hill, New York, New York, 1970. Library of Congress Catalog Card No. 73-79497.

John Vossen and Werner Kern, Eds., Thin Film Processes, Academic Press, New York, New York, 1978. ISBN 0-12-728250-5.

John L. Vossen and Werner Kern, Eds., Thin Film Processes II, Academic Press, San Diego, CA, 1991. ISBN 0-12-728251-3.

Brian Chapman, Glow Discharge Processes, John Wiley and Sons, New York, New York, 1980. ISBN 0-471-07828-X.

Stephen M. Rossnagel, Jerome J. Cuomo and William D. Westwood, Eds., Handbook of Plasma Processing Technology, Noyes Publications, Park Ridge, New Jersey, 1990. ISBN 0-8155-1220-1.

Kiyotaka Wasa and Sahigeru Hayakawa, Handbook of Sputter Deposition Technology, Noyes Publications, Park Ridge, New Jersey, 1992. ISBN 0-8155-1280-5.

Maurice H. Francombe, John L. Vossen, Eds., Plasma Sources for Thin Film Deposition and Etching, Volume 18, Academic Press, San Diego, CA, 1994. ISBN 0-12-533018-9.

R. V. Stuart, Vacuum Technology, Thin Films and Sputtering, Academic Press, Orlando, FL, 1983. ISBN 0-12-673780-6

Donald L. Smith, Thin Film Deposition Principles & Practice, McGraw-Hill, New York, NY, 1995. ISBN 0-07-058502-4.

Application Note -Grounding, Advanced Energy Industries, Inc., 1625 Sharp Point Drive, Fort Collins, CO 80525, 1991. Tel: (970) 221-4670.

Harold C. Ritchey, Application Note - Tuner Topics, Advanced Energy Industries, Inc., 1625 Sharp Point Drive, Fort Collins, CO 80525, 1988. Tel: (970) 221-4670.

Larry Knipp and Gary Johnson, Application Note - Basic RF Principles, Advanced Energy Industries, Inc., 1625 Sharp Point Drive, Fort Collins, CO 80525, 1990. Tel: (970) 221-4670.

Technote 34 - Impedance Matching, Advanced Energy Industries, Inc., 1625 Sharp Point Drive, Fort Collins, CO 80525, 1992. Tel: (970) 221-4670.

**DOCUMENT NO. 251010, Rev. B  
INSTALLATION, OPERATION AND  
USE OF POLARIS™ PLANAR  
MAGNETRON CATHODES  
6 FEBRUARY 2003**

**9.0 TROUBLESHOOTING**

**9.1 Target Overheating**

Dramatic, immediate changes in voltage and/or current are indications of target overheating.

Check for:

- Inadequate water flow
- Inlet water temperature not per specification
- Poor target bonding or target clamping
- Higher than permissible power density per duty cycle

**9.2 Plasma Will Not Ignite**

Verify:

- All power supply/system interlocks (water/pressure/flow) are satisfied
- Argon gas pressure at cathode is sufficient
- Power supply is properly connected to the cathode and chamber
- Chamber pressure is not too high
- Water leaks are not causing shorting
- No shorts between cathode and ground shield caused by whisker growth, flaking and debris
- Insulator surfaces (not outside surface of bolt insulators) are not coated or conductive
- Magnet module has not been overheated or weakened
- Excessively thick magnetic targets are not being used
- Target material is electrically conductive when using a DC power supply

**DOCUMENT NO. 251010, Rev. B  
INSTALLATION, OPERATION AND  
USE OF POLARIS™ PLANAR  
MAGNETRON CATHODES  
6 FEBRUARY 2003**

**10.0 APPENDIX**

**10.1 Parts Included With New Cathode**

*2" (50mm) Internal Cathodes*

- 1 ea P/N 00000156 SS-2-UT-6 Cajon 1/8" UltraTorr Coupling
- 2 ea 60" long 1/4" or 6 mm OD Teflon TFE Tubing
- 1 ea 1/8" OD x 12" long Teflon PFA Tubing
- 1 ea 1/4" OD water tube clip

**10.2 Spare Parts Included With New Cathode**

*2" (50 mm) Internal Cathodes*

- 1 ea P/N 00000153-2226 Viton O-Ring (Backing Plate/Target Seal)
- 2 ea P/N 00000153-2223 Viton O-Ring (Body Insulator)
- 1 ea P/N 00000153-2008 Viton O-Ring (Argon Gas Inlet Face Seal)
- 3 ea P/N 00000153-2006 Viton O-Ring (Cajon Ultra-Torr Fittings)
- 1 ea P/N 00000153-2326 Viton O-Ring (KF-40 Centering Ring)
  
- 6 ea P/N 00000071 Teflon Bolt Insulator
- 6 ea P/N 00000008 Teflon Bolt Insulator Cap
  
- 6 ea M3 x 25 Chemically Cleaned SST Socket Head Cap Screw (Bolt Insulators)
- 6 ea M3 Chemically Cleaned Flat Washer (Bolt Insulators)
- 4 ea M3 x 6 Chemically Cleaned Socket Head Cap Screw (Ground Shield and Power Connection)
- 3 ea M3 x 6 Chemically Cleaned Flat Head Cap Screw (Backing Plate)
- 6 ea M3 x 12 Chemically Cleaned Flat Head Cap Screw (Clamping Ring)
  
  
- 2 ea Parker 68P-4-2 Male Connector
- 4 ea Parker 60P-4 Acetyl Plastic Sleeve
- 2 ea 9/16" OD x 1" long Teflon TFE Insulating Sleeves (Water Fittings)

*KF-40/1" Baseplate Feedthrough*

- 1 ea P/N 00000153-2216 Viton O-Ring (1" Baseplate Feedthrough)

**DOCUMENT NO. 251010, Rev. B  
 INSTALLATION, OPERATION AND  
 USE OF POLARIST™ PLANAR  
 MAGNETRON CATHODES  
 6 FEBRUARY 2003**

**10.3 Standard Magnet Module Field Profiles  
 10.3.1 2"/50mm Magnet Module**

Data shown on table below is graphically displayed on following pages.

Target Radius	B Horizontal Gauss	B Vertical Gauss	B Horizontal Gauss	B Vertical Gauss	B Horizontal Gauss	B Vertical Gauss	B Horizontal Gauss	B Vertical Gauss	B Horizontal Gauss	B Vertical Gauss
<b>Height Above Magnet Surface</b>	On Magnet Surface	On Magnet Surface	On 0.060" Backing Plate (*)	On 0.060" Backing Plate (*)	0.125" Thick Target On Backing Plate (*)	0.125" Thick Target On Backing Plate (*)	0.25" Thick Directly Water Cooled Target	0.25" Thick Directly Water Cooled Target	0.25" Thick Target On Backing Plate (*)	0.25" Thick Target On Backing Plate (*)
<b>0"</b>	0	-2900	0	-1600	0	-920	0	-700	0	-430
<b>0.125"</b>	-550	-2420	-590	-1177	-130	-780	-110	-580	-178	-294
<b>0.25"</b>	-1374	-1340	-918	-714	-353	-557	-320	-344	-272	-143
<b>0.375"</b>	-1572	-637	-986	-220	-540	-227	-405	-122	-301	-5
<b>0.50"</b>	-1400	-59	-907	296	-555	93	-410	153	-277	163
<b>0.625"</b>	-1260	1167	-762	707	-485	302	-318	330	-194	262
<b>0.75"</b>	-904	1597	-323	883	-290	477	-160	400	-59	290
<b>0.875"</b>	358	936	282	560	-45	460	23	358	85	232
<b>1.0"</b>	905	343	535	175	222	244	190	212	200	172

Note: "\*" indicates use of 0.060" thick backing plate.

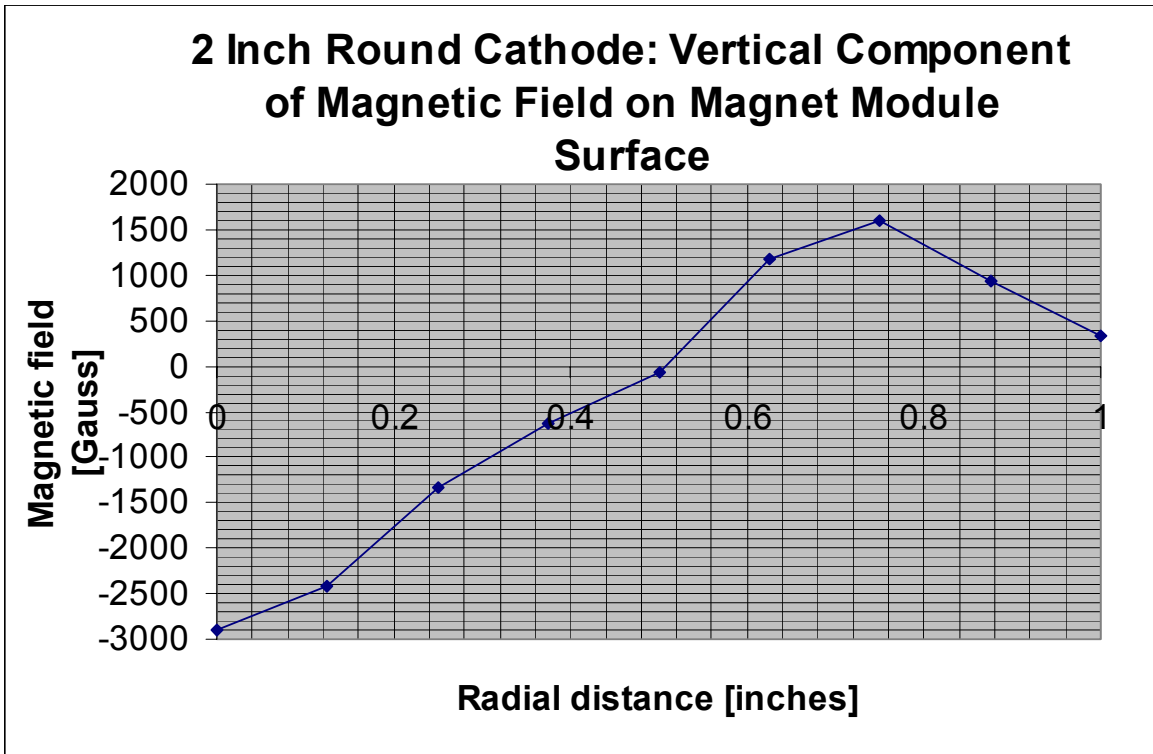
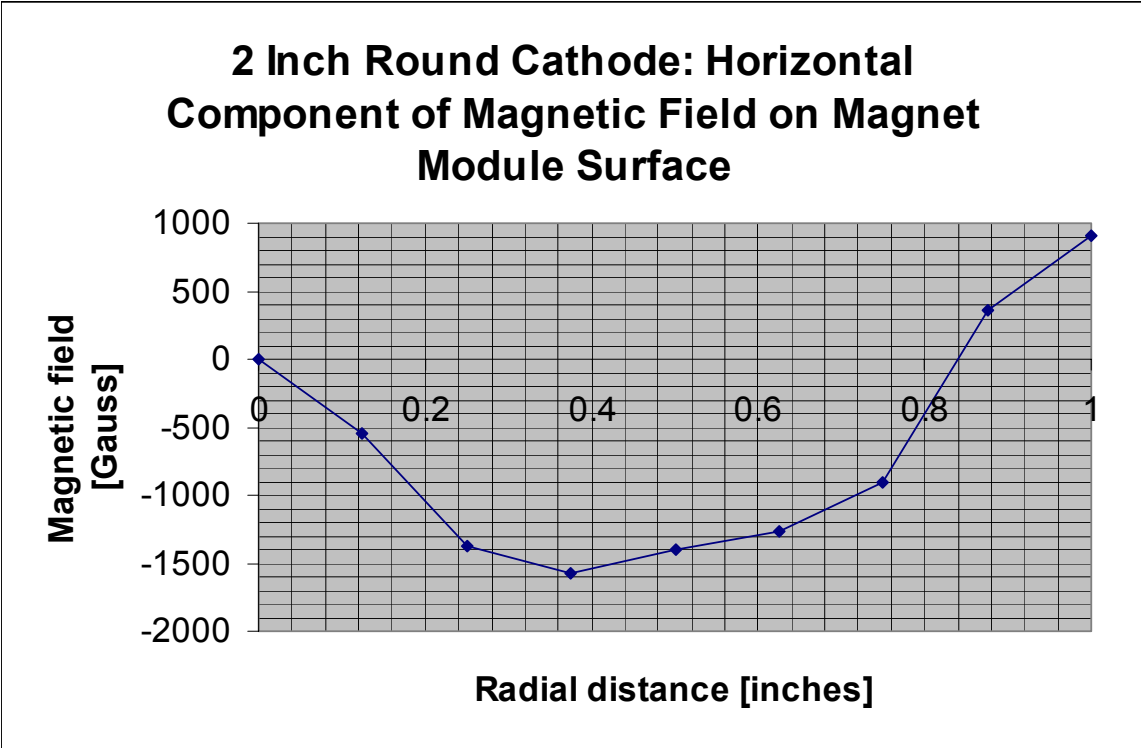

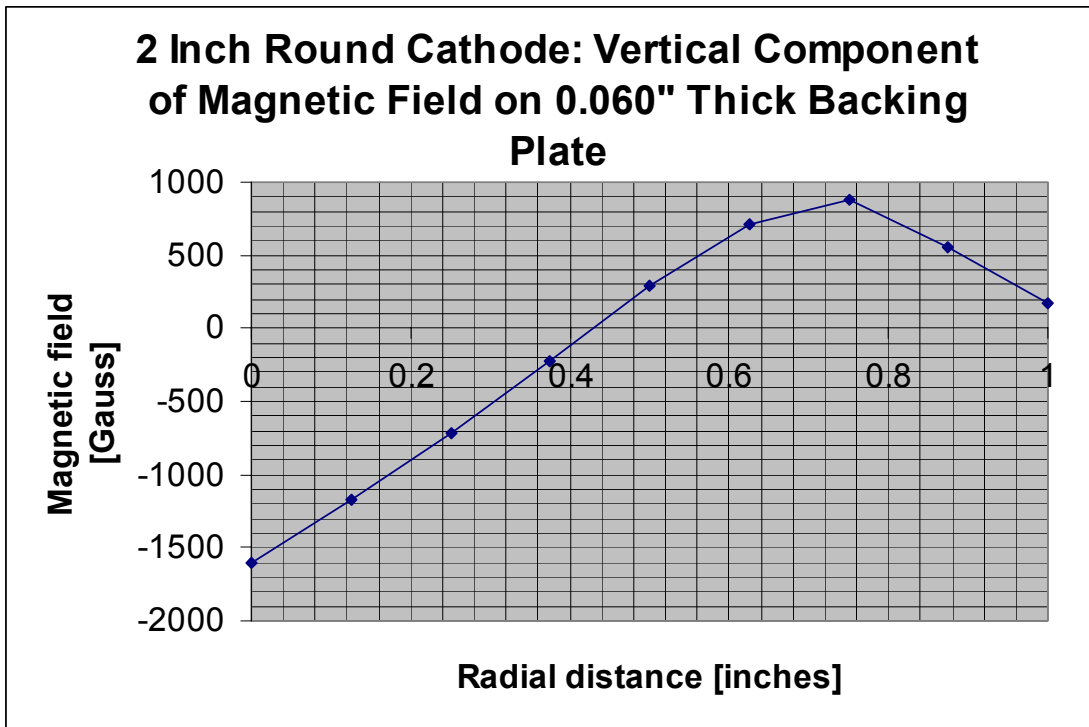
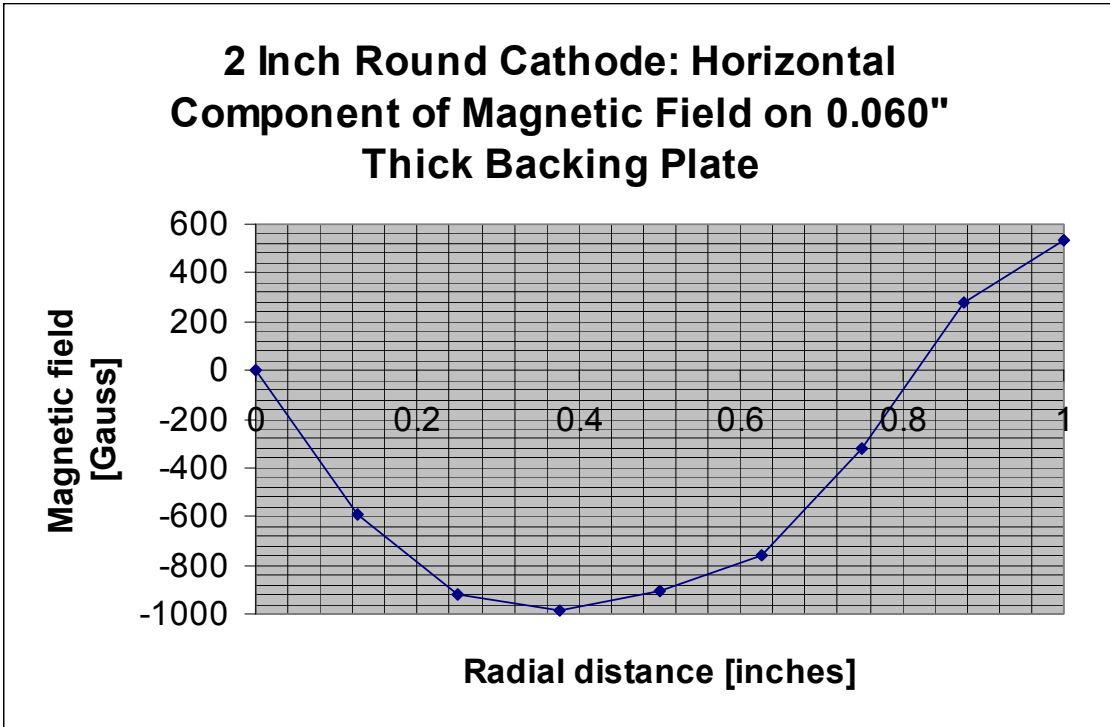

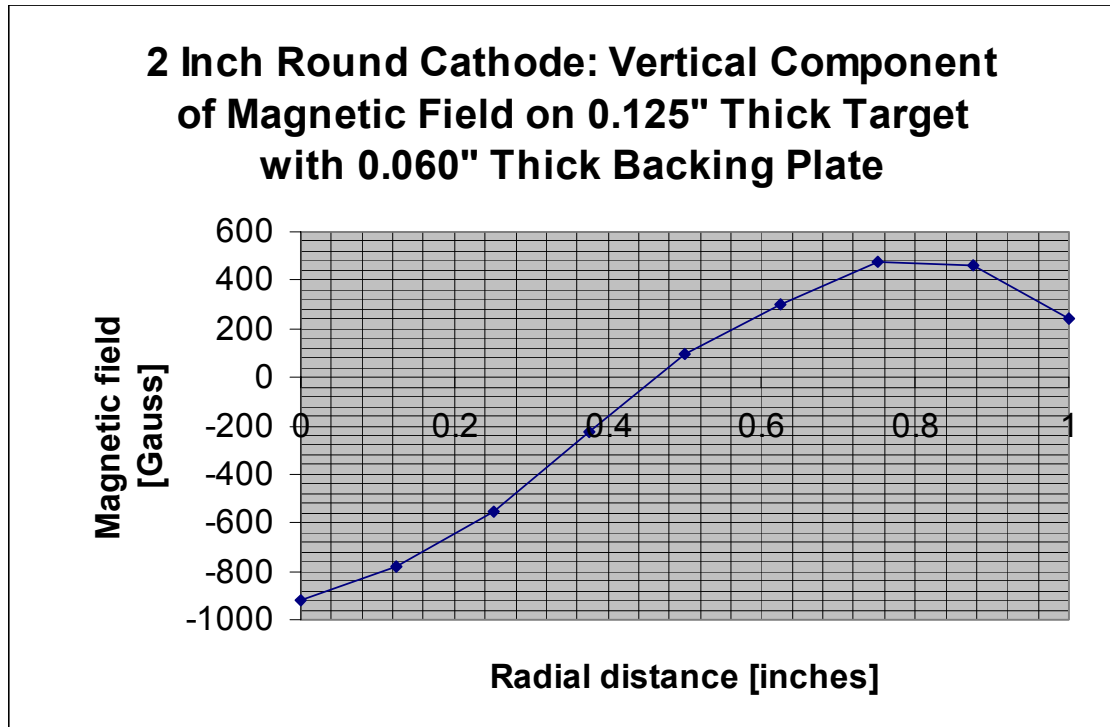
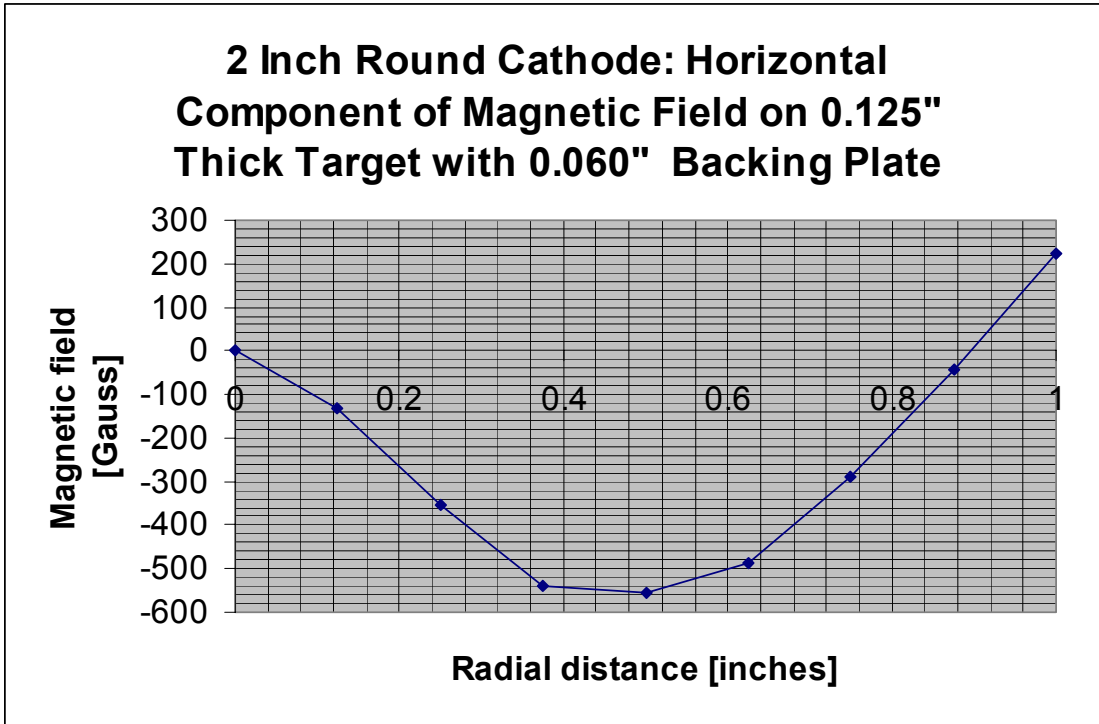

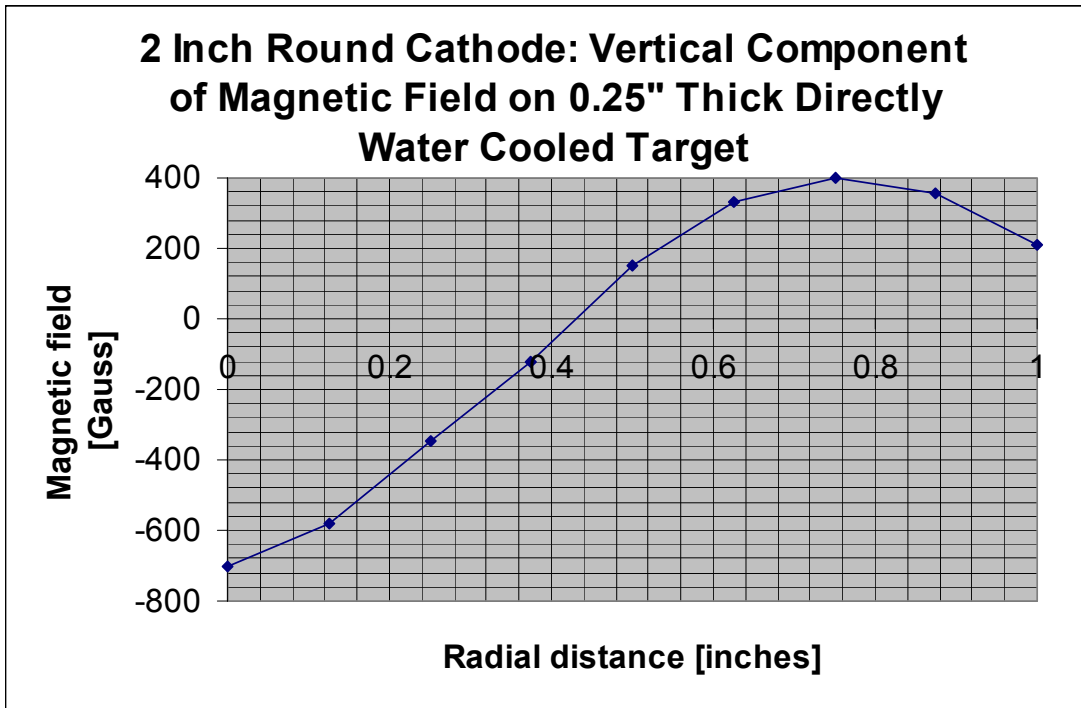
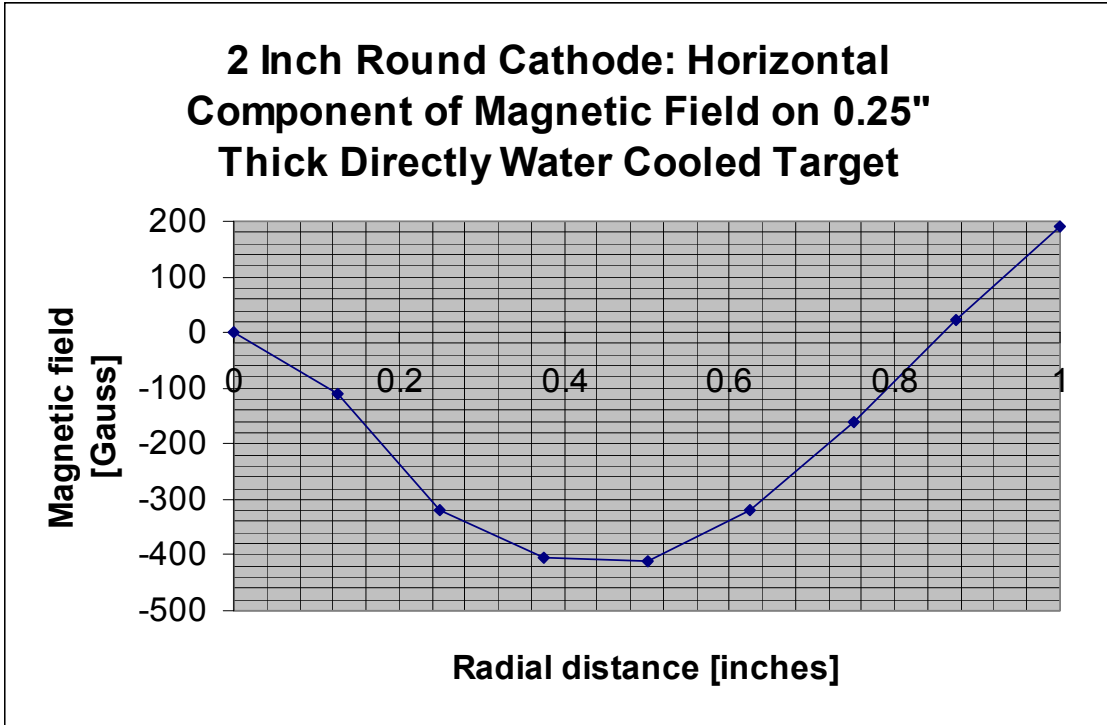

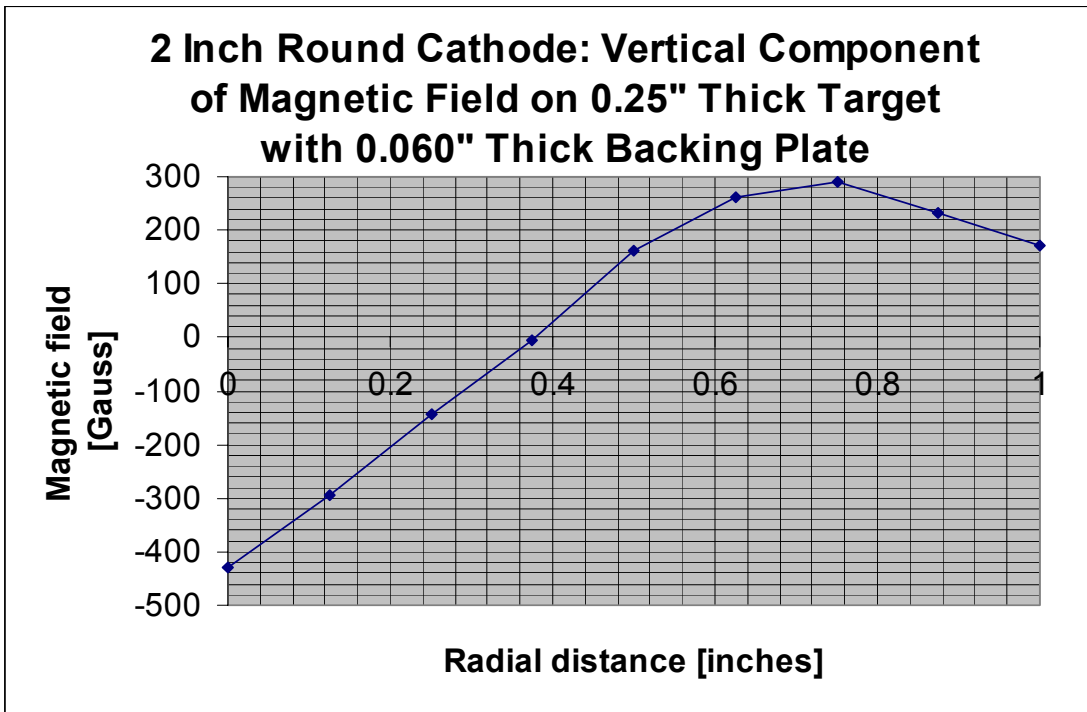
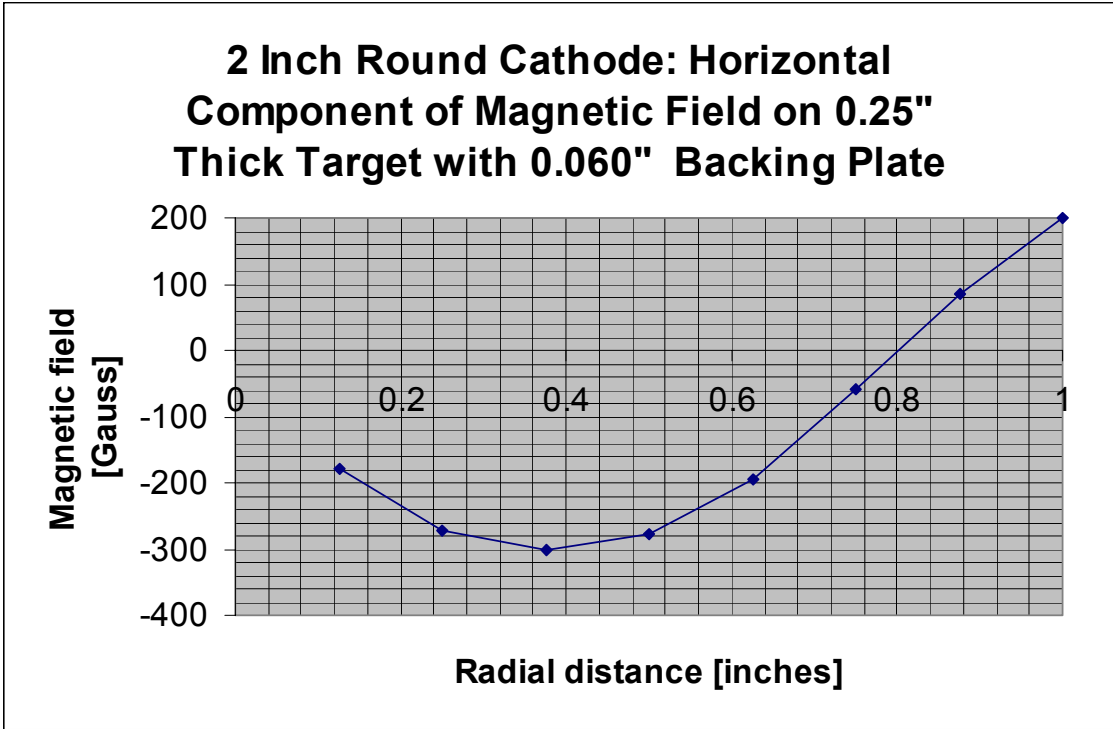

**DOCUMENT NO. 251010, Rev. B  
INSTALLATION, OPERATION AND  
USE OF POLARIS™ PLANAR  
MAGNETRON CATHODES  
6 FEBRUARY 2003**

**10.4 Assembly Level Drawings**

Full size assembly prints for the particular item purchased are provided with this manual.

<u>DRAWING</u>	<u>DESCRIPTION</u>
00000017	KF-40/1" Baseplate DC/RF Feedthrough Assembly
00000018	KF-40/1" Baseplate DC Feedthrough Assembly
00000049	2"/50mm Internal Cathode, RF/DC KF-40/1" Baseplate Feedthrough
00000055	2"/50mm Internal Cathode, KF 40 Quick Flange Mount
00000056	2"/50mm Internal Cathode, 1" Baseplate DC Feedthrough